



**The University of Jordan
School of Engineering
Mechanical Engineering Department**

Mechanical Vibration Lab

(0954412)

Insert Your Course Name Here
(Course #)
Short or Full Lab Report



**School of Engineering
The University of Jordan, Amman-Jordan**

Project/Experiment/Report Title Goes here

by

**FirstName Initial LastName (ID #)
FirstName Initial LastName (ID #)**

Section #:

Month 9999

Abstract

An abstract consists of answering three basic questions:

1. What was done?
 2. How it is was done? and
 3. What were the basic findings and conclusions?
- ✓ Abstract should be written in passive voice.
 - ✓ Abstract should not exceed 200 words.
 - ✓ It should be written in three separate paragraphs.
 - ✓ This section and all the coming sections should be written in Font 12, Times New Roman with regular style and single line spacing.
 - ✓ This page should contain the abstract ONLY and numbered using the Roman Style (i.e. I, ii, iii ...etc)
 - ✓ It should be written in passive voice.

Nomenclature

The nomenclature defines the parameters, symbols and acronyms used in the report. Standardized symbols should be used whenever possible.

- The units should be added to the nomenclature.
- The parameters should be arranged alphabetically.
- This section should be written in separate page(s).

A	Area	[m ²]
P	Pressure	[N/m ²]
Re	Reynolds Number	[ND]

Subscript

f	Liquid
s	surface

Greek Symbols

μ	Dynamic viscosity	[N-s/m ²]
α	Angle of attack	[deg]

Objective

The objective(s) should be written based on the instructor's explanation of the experiment.

DO NOT copy from laboratory manual.

Experimental Setup and Procedure

This section should contain the working principle of the setup used in the experiment. It should contain a clear image of the setup with the main parts identified in suitable manner.

The figure's caption (name) should be written below it.

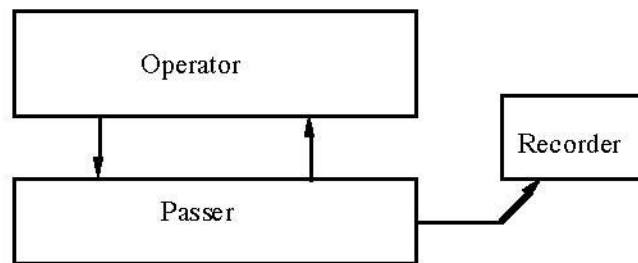

Figure (1): Some numbers from the result of the experiment on nothing

- ✓ Never start any paragraph with figure, table, graph ...etc. You should always write few introductory lines (e.g. This section discusses the setup used in conducting this experiment. The setup is shown below in Figure (1)).
- ✓ Define the major components of the setup.
- ✓ Explain briefly how it works.
- ✓ Finally, explain with your own words (DO NOT COPY FROM USER MANUAL) how you conducted the experiment.
- ✓ As of this page onwards, the page numbering should start using the 1-100 Arabic numbers.

Data Observation

The data observed are divide into two main items.

Given data

- This includes the constants that were not changed in the experiment e.g atmospheric conditions, certain setup dimensions (if not changed) e.g diameter, lengthetc.
- As for the material's properties e.g, density, viscosity, thermal conductivity ...etc these should be mentioned with the reference wherefrom they were copied cited.

Observed data

- ✓ The data that were taken from the setup ONLY should be mentioned in the table.

- ✓ Table columns should be written with units and without abbreviations.
- ✓ The table caption should be mentioned on top of the table.
- ✓ Do not add any calculated data in the table.

(1)
Table (1): The observed data

Trial #	Quantity 1 [unit]	Quantity 2 [unit]
1	4.0	4.9×10^{-2}
2	3.2	4.5×10^{-2}
3	2.8	4.4×10^{-2}

If the experiment consists of several parts, put the tables with each case defined before that.

For example :

Case (I) : Partially submerged torous

Inset the data observed table for this case below.

Case (II) : Totally submerged torous

Inset the data observed table for this case below.

Sample calculations

In this section you are required to provide with proper explanation (NOT only use equations and substitute numbers) the steps for your calculations.

You should state which data you are taking for sample calculations.

If the calculations involve theoretical and experimental values for comparison, you should calculate the percentage error in the experimental value.

Uncertainty analysis

This is extremely important part that tells the accuracy of the test procedure (NOT ONLY in the final value).

This can be extremely helpful if one wishes to find the main factor responsible for the error.

There are many methods suggested for this section :

- 1) Uncertainty propagation (you can use suitable software for that as you have been taught)
- 2) Limiting and relative limiting errors using equations.
- 3) Limiting and relative limiting errors using maximum/minimum method.

Finally a summary of the calculations should be added in separate table(s) with errors and uncertainty calculations.

Results and discussion

Present your results logically, highlighting what is important and how the data you obtained have been analyzed to provide the results you discuss.

- **You should discuss what you infer from the data.**
- **You need to adopt a critical approach.**
- **For example, discuss the relative confidence you have in different aspects of the measurements.**
- **Make sure that all diagrams, graphs etc. are properly labelled and have a caption.**

(2)

- **A neat hand drawn diagram is preferable to a poorly made computer diagram, or a poor resolution image copied from the web.**

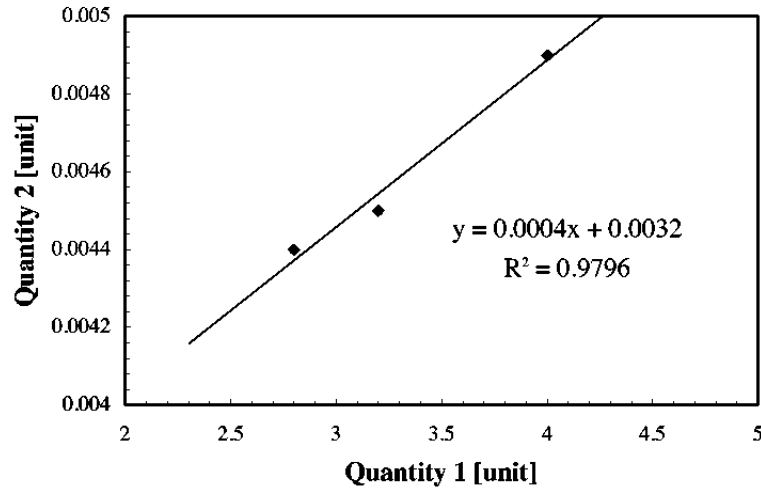

Figure 2 Quantity 1 versus Quantity 2



Figure (2) : Variation of Quantity (2) with Quantity (1)

- Graphs should be clear, informative, with proper legends and units.
- If curve fitting is implemented, it should contain the fit model and its R².
- Graph outline should be removed.

Conclusion

This is the section in which you need to put it all together. It differs from the abstract in that :

- 👉 **It should be more informative, something that can easily be accomplished because you may devote more words to it. You should include a concise version of your discussion, highlighting what you found out, what problems you had, and what might be done in the future to remedy them.**
- 👉 **You should also indicate how the investigation could usefully be continued.**

References

For this section, you should provide the source of information wherefrom you got the equations, fluid or materials properties.

Use this website: <https://scholar.google.com/>

- ✓ Textbooks, articles, and company websites are trusted sources.
- ✓ Do not use the lab manual as a reference.
- ✓ List the references in the same order as they appear in the text.
- ✓ For my students, I ask them to use the APA or Chicago style.

Book

Holman, J. P. (2012). Experimental methods for engineers. McGrawHill, New Yourk.

(3)

Journal article,

Sang, J., Yuan, Y., Yang, W., Zhu, J., Fu, L., Li, D., & Zhou, L. (2022). Exploring the underlying causes of optimizing thermal conductivity of copper/diamond composites by interface thickness. *Journal of Alloys and Compounds*, 891, 161777.

Web page,

<http://www.gobbeldygook.co.uk>. Viewed on 22/10/2020.

A word of caution on web-based information. Journal articles and most books are peer-reviewed. This means that other workers in the field have checked them for accuracy etc.. This is not true of websites. Be careful in taking information from such sources and ,if at all possible, verify the information by checking in books etc. You should also read the web information critically to see that it makes sense to you. You are an engineer and should take pride in not being duped into making easy mistakes by faulty information

Simple & Compound Pendulums

I- Introduction:

A simple pendulum is simply a concentrated mass m attached to one of the ends of a mass-less cord of length l , while the other end is fitted as a point of oscillation, such that the mass is free to oscillate about that fixed point in the vertical plane. The compound pendulum differs from the simple one in that it has a mass distribution along its length, -that is its mass is not concentrated at a given point-, therefore it has a mass moment of inertia I about its mass centre.

Any rigid body that has a mass m , and mass moment of inertia I and is suspended at a given distance h from its centre of gravity represents a compound pendulum.

It should be realised in the derivation of the governing equations, that the angle of oscillation of the pendulum, simple or compound, should be small.

II- Objectives:

This experiment aims at studying the behaviour of both simple and compound pendulums, in order to realise the following objectives:

- 1) The independence of the period of oscillation of the simple pendulum from its mass.
- 2) The relationship between the period of oscillation and its length.
- 3) The determination of the value of the gravitational acceleration g , to be compared with the known standard value.

III- System Description:

Part One- Simple Pendulum:

The schematic representation of the simple pendulum is shown in *Figure-1.1-a*, which consists of a small ball of mass m suspended by a mass-less cord of length l . The system is given an initial small angular displacement Θ , and as a result the pendulum oscillates in the vertical plane by a time varying angle $\theta(t)$ with the vertical direction.

Part Two- Compound Pendulum:

The compound pendulum is schematically shown in *Figure-1.2-b* below, and it consists of a uniform slender bar of total mass m and length l , which may be suspended at various points A along the bar with the aid of a sliding pivot situated at any distance h from the centre of gravity of the pendulum.

(For this case, the centre of mass is at the middle of the rod).

As a result of an initial angular displacement θ , the pendulum oscillates also with a time-varying angle $\theta(t)$ with the vertical direction.

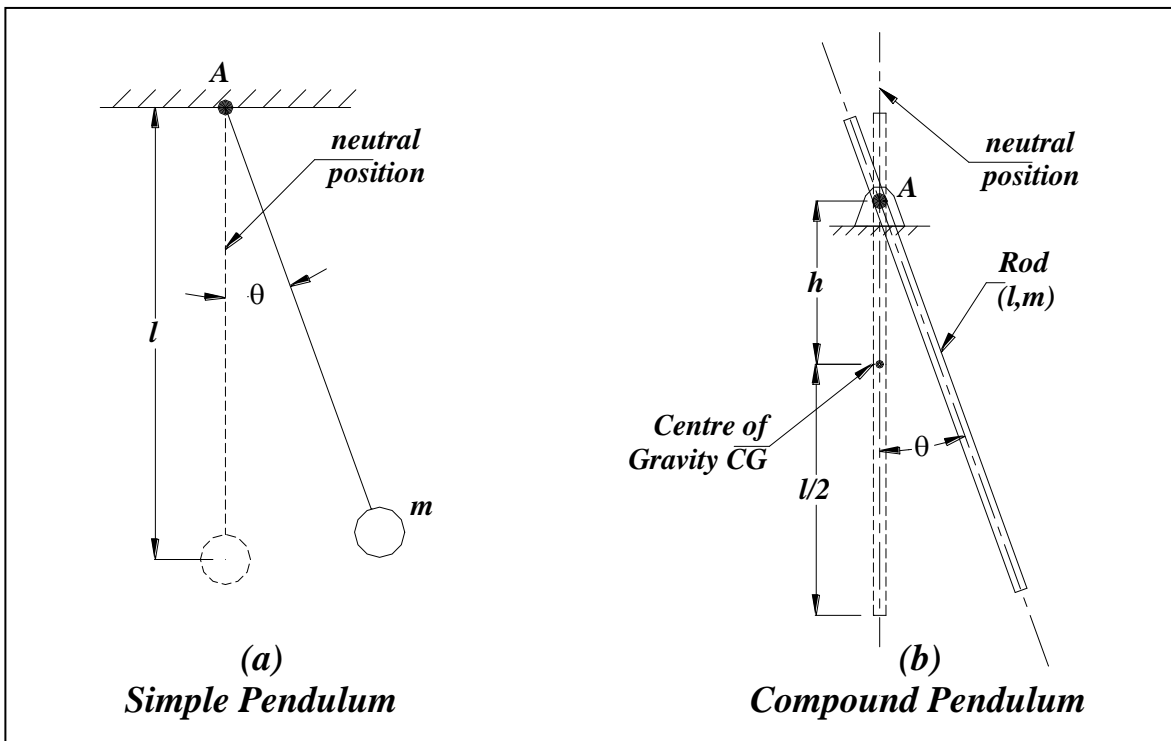

Figure-1.1 Schematic representation of the
(a) simple pendulum (b) compound pendulum

IV- Governing Equations:

Part One - Simple Pendulum:

The dynamic equilibrium equation (*equation of motion*) corresponding to the tangential direction of motion of the concentrated mass yields:

$$ml\ddot{\theta} + mg \sin \theta = 0 \quad (1)$$

Assuming a small magnitude for the angle θ , so that $\sin \theta \approx \theta$, and simplifying eqn-1 leads to the equation:

$$\ddot{\theta} + \frac{g}{l} \theta = 0 \quad (2)$$

Let the motion defined by the function $\theta(t)$ be a simple harmonic motion defined as $\theta(t) = \Theta \sin \omega_n t$, where ω_n is the natural frequency of the pendulum. Substituting for θ in eqn-2 and simplifying gives ω_n as:

$$\omega_n = \sqrt{\frac{g}{l}} \quad (3)$$

The period of oscillation (τ), is defined as the time required to complete one full cycle of motion or one oscillation. By observing the function $\theta(t)$, the period τ is given as:

$$\tau = \frac{2\pi}{\omega_n} = 2\pi \sqrt{\frac{l}{g}} \quad (4)$$

Part Two- Compound Pendulum:

For the compound pendulum, the dynamic equilibrium equation is obtained by taking the moments about pivot point A as given below:

$$I_A \ddot{\theta} + mgh \sin \theta = 0 \quad (5)$$

where; I_A is the mass moment of inertia of the rod about the pivot point A.

Assuming a small angle of oscillation and simple harmonic motion for $\theta(t)$, leads to the following expressions for the natural frequency ω_n and period τ , respectively:

$$\omega_n = \sqrt{\frac{mgh}{I_A}} \quad (6)$$

$$\tau = 2\pi \sqrt{\frac{I_A}{mgh}} \quad (7)$$

The mass moment of inertia about the pivot point I_A , is defined in terms of the mass moment of inertia about the centre of gravity I_{CG} and the distance h between the centre of gravity and the pivot point A as:

$$I_A = I_{CG} + mh^2 \quad (8)$$

or

$$I_A = m(K_{CG}^2 + h^2) \quad (9)$$

where; K_{CG} is the radius of gyration of the rod about the centre of gravity.

Using eqns-7 & 9, then the period of oscillation of the compound pendulum is given by the expression:

$$\tau = 2\pi \sqrt{\frac{K_{GC}^2 + h^2}{gh}} \quad (10)$$

V- Experimental Procedures:

Part One- Simple Pendulum:

Steel and plastic balls are used separately in this experiment as follows:

- 1) Attach the cord to the steel ball at one end, and attach the other end to the main frame. Record the length of the cord l .
- 2) Displace the ball from its neutral position by a small amount, and then release it to oscillate freely. Measure and record the time T required to complete ten oscillations.
- 3) Adjust the cord length to a new value and repeat step-2.
- 4) Repeat Step-3 six more times so that eight pairs of l and T are recorded.
- 5) Replace the steel ball with the plastic ball and repeat steps-1 through 4.

Part Two- Compound Pendulum:

The experimental procedures for the compound pendulum part are carried out through the following steps:

- 1) Measure and record the total length l of the rod. Since the rod is uniform, the geometrical centre point coincides with the rod's centre of gravity CG .
- 2) Pivot the rod at an arbitrary point A , and measure the distance from that point to the centre of gravity h . Displace the rod by a small angle from its neutral position and release it freely, then measure and record the time required to complete ten oscillations T .
- 3) Change the pivoting point A and repeat step-2.
- 4) Repeat step-3 eight more times so that ten pairs of h and T are recorded.

VI- Collected Data:

Part One- Simple Pendulum:

Table-1.1 Collected data for the simple pendulum part

Trial	Steel Ball		Plastic Ball	
	<i>l (cm)</i>	<i>T (second)</i>	<i>l (cm)</i>	<i>T (second)</i>
1				
2				
3				
4				
5				
6				
7				
8				

Part Two- Compound Pendulum:

l =cm

Table-1.2 Collected data for the compound pendulum part

Trial	<i>h (cm)</i>	<i>T (second)</i>
1		
2		
3		
4		
5		
6		
7		
8		
9		
10		

VII- Data Processing:

Part One- Simple Pendulum:

Use eqn-4: $\tau = 2\pi \sqrt{\frac{l}{g}}$	Evaluate the theoretical period τ_{Theor} corresponding to each length l .	The values of τ_{Theor} are to be compared with the experimental values τ_{Exper} .
Square both sides of eqn-4 to get: $\tau^2 = 4\pi^2 \frac{l}{g}$	Draw τ^2 versus l as shown in Figure-1.2.	Slope = $\frac{4\pi^2}{g}$ $\Rightarrow g$ is found and compared to the standard value.

Part Two- Compound Pendulum:

Square eqn-10 and rearrange to get: $\tau^2 h = \frac{4\pi^2}{g} (K_{CG}^2 + h^2)$	Draw $\tau^2 h$ versus h^2 as shown in Figure-1.3.	1- Slope = $\frac{4\pi^2}{g}$ \Rightarrow find g and compare it to the standard value. 2- Intercept with the vertical axis $Y_{Int} = \left(\frac{4\pi^2}{g}\right) K_{CG}^2$ $\Rightarrow K_{CG}$ is obtained. 3- Intercept with the horizontal axis $X_{Int} = -K_{CG}^2$ $\Rightarrow K_{CG}$ is verified.
From eqn-10: $\tau = 2\pi \sqrt{\frac{K_{CG}^2 + h^2}{gh}}$	Draw τ versus h as that in Figure-1.4.	Find τ_{min} and the corresponding value of h .
Differentiate eqn-10 to find that at $h = K_{CG}$, the value of τ_{min} is given by: $\tau_{min} = \sqrt{\frac{8\pi^2 K_{CG}}{g}} \quad (11)$	Determine the values of τ_{min} and h .	Compare the values of τ_{min} and h obtained from both; Figure-1.4 and eqn-11.

VIII- Results:

Part One- Simple Pendulum:

Table-1.3 Data processing analysis for the simple pendulum part

Steel Ball					
Trial	l (cm)	τ_{Exper} (second)	τ_{Theor} (second)	$(\tau_{Exper.})^2$ (second)²	τ Percent Error (%)
1					
2					
3					
4					
5					
6					
7					
8					

Table-1.4 Data processing analysis for the simple pendulum part

Plastic Ball					
Trial	l (cm)	τ_{Exper} (second)	τ_{Theor} (second)	$(\tau_{Exper.})^2$ (second)²	τ Percent Error (%)
1					
2					
3					
4					
5					
6					
7					
8					

Table-1.5 Data processing results for the simple pendulum part.

Quantity	Slope from Figure-1.2:	g (m/s²)	Percentage Error of g (%)
Steel Ball			
Plastic Ball			

Part Two- Compound Pendulum:

Table-1.6 Data processing analysis for the compound pendulum part

Trial	<i>h</i> (cm)	<i>τ</i> (second)	<i>h</i>² (cm)²	<i>τ</i>²<i>h</i> (cm.sec²)
1				
2				
3				
4				
5				
6				
7				
8				
9				
10				

Table-1.7 Data processing results for the compound pendulum part

<i>From Figure-1.3</i>		
<i>Slope</i> (sec.²/m)	<i>g</i> (m²/sec.)	<i>Percent Error</i> (%)
<i>Y_{Int}</i> (sec².m)	<i>K_{CG}</i> (cm)	
<i>X_{Int}</i> (m²)	<i>K_{CG}</i> (cm)	<i>Percent Error</i> (%)

<i>From Figure-1.4</i>	<i>From Eqn-11</i>	
<i>τ_{min}</i> (sec.)	<i>τ_{min}</i> (sec.)	<i>Percent Error</i> (%)
<i>h at τ = τ_{min}</i> (cm)	<i>h</i> (cm)	<i>Percent Error</i> (%)

Centre of Percussion & Kater's (Reversible) Pendulum

I- Introduction:

The centre of percussion is the point within a suspended body (*a compound pendulum*) at which that body can be given an impulsive force without any reaction formation at the point of suspension.

This concept has an extensive importance in the design of many engineering applications and tools, in which it is necessary to minimise or eliminate reactive forces at swivel points. An example of that is the Hammer, which is designed to have its centre of percussion at its bulkhead, with respect to the pivot point (*the point of handling*); and as a result, the person holding the hammer will be free of reactions while using it.

Other practical applications are Baseball and Cricket bats.

Kater's Pendulum (*Reversible Pendulum*) is just a method employing a specific form of compound pendulums for accurate determination of the gravitational acceleration g .

II- Objectives:

In this experiment, the following aims shall be realised:

- 1) Demonstration and examination of the concept of the centre of percussion.
- 2) Understanding the technique of finding the radius of gyration and then the centre of percussion of the compound pendulum using time measurements.
- 3) Determination of the gravitational acceleration constant g using the reversible pendulum.
- 4) Estimation of the theoretical period of oscillation of the reversible pendulum at each configuration, to be compared with the experimental value.
- 5) Finding the length of the reversible pendulum that has an equivalent reverse length (*with the same period of oscillation*).

III- System Description:

Part One- Centre Of Percussion:

The schematic representation of the system used in the experiment is shown in *Figure-2.1* below, which shows a compound pendulum that consists of a rigid rectangular block, and a small mass, which is able to slide freely in a central slot within the block.

The pendulum is pivoted at point *A*, and the slide-able mass is positioned at distance *Y* from point *A*, so the corresponding position of the centre of gravity of the system is at distance *h* from point *A*. That is; the centre of gravity of the system is altered by changing the position of the slideable mass.

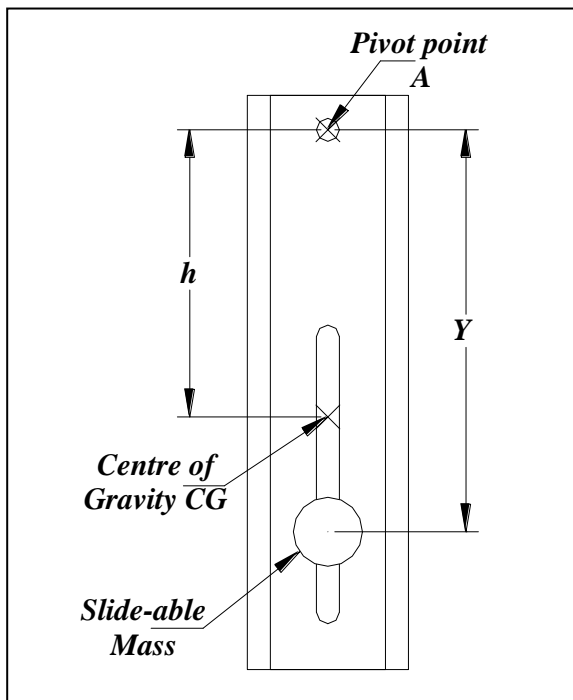

Figure-2.1 Layout of the Centre of Percussion part

Part Two- Reversible Pendulum:

The reversible pendulum shown schematically in *Figure-2.2* is simply a compound pendulum with two points of suspension A_1 & A_2 . It consists of a uniform circular cross-section rod of mass $M = 0.680 \text{ kg}$, and length L ; provided with two knives as pivot points at both ends A_1 and A_2 .

A slide-able metal cylinder of mass $m = 1.1 \text{ kg}$ is adjusted at any distance Y_1 from A_1 , and distance Y_2 from A_2 ; and as a result of this, the centre of gravity CG of the whole assembly will be at distance h_1 from A_1 , and h_2 from A_2 .

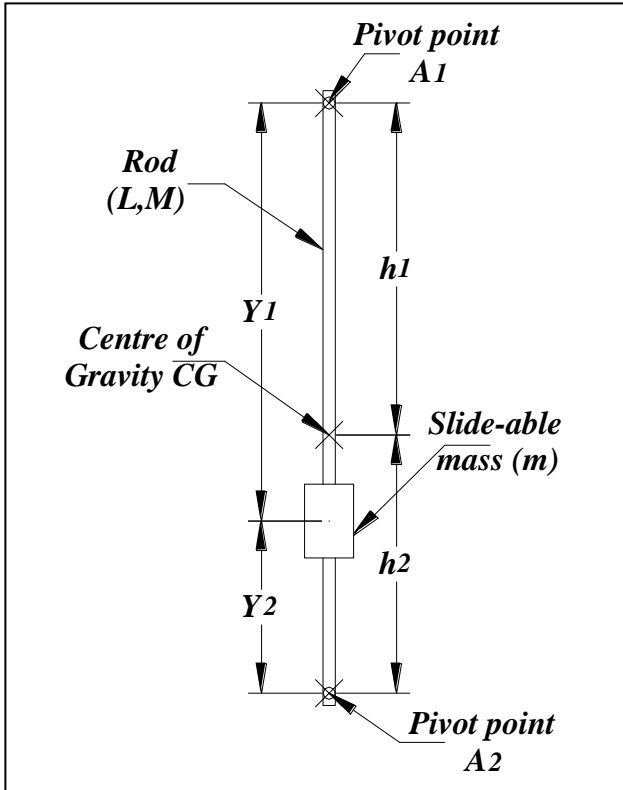

Figure-2.2 Layout of the Reversible Pendulum part

IV- Governing Equations:

Part One- Centre Of Percussion:

For the system shown in Figure-2.1, the equation of motion is simply that for a compound pendulum, that is:

$$I_A \ddot{\theta} + (Mgh)\theta = 0 \quad (1)$$

And so, we can find that:

$$* \text{Natural frequency} = \omega_n = \sqrt{\frac{Mgh}{I_A}} \quad (2)$$

$$* \text{Period of oscillation} = \tau = \frac{2\pi}{\omega_n} = 2\pi \sqrt{\frac{I_A}{Mgh}} \quad (3)$$

But, from the definition of the mass moment of inertia I :

$$I_A = MK_A^2$$

$$K_A^2 = K_{CG}^2 + h^2$$

Then, the mass moment of inertia about point A is written as:

$$I_A = M(K_{CG}^2 + h^2) \quad (4)$$

where; K_A is the radius of gyration about point A .

K_{CG} is the radius of gyration about the centre of gravity CG .

By substitution in eqn-3, it becomes:

$$\tau = 2\pi \sqrt{\frac{K_A^2}{gh}} \quad (5)$$

Define the equivalent length of the compound pendulum as l_{equ} , then:

$$l_{equ} = \frac{K_A^2}{h} = h + \frac{K_{CG}^2}{h} \quad (6)$$

Part Two- Reversible Pendulum:

The system shown in *Figure-2.2* also represents a compound pendulum when suspended at either A_1 or A_2 , so it follows the same form of eqn-1. And as a result, we find that:

$$\tau_1 = 2\pi \sqrt{\frac{K_{A1}^2}{gh_1}} = 2\pi \sqrt{\frac{K_{CG}^2 + h_1^2}{gh_1}} \quad (7)$$

$$\tau_2 = 2\pi \sqrt{\frac{K_{A2}^2}{gh_2}} = 2\pi \sqrt{\frac{K_{CG}^2 + h_2^2}{gh_2}} \quad (8)$$

Theoretically, to find out the centre of gravity of the assembly at any given configuration, then:

$$h_1 = \frac{\frac{ML}{2} + mY_1}{M + m} \quad (9)$$

$$h_2 = \frac{\frac{ML}{2} + mY_2}{M + m} \quad (10)$$

Also, the radius of gyration about the centre of gravity K_{CG} is given by:

$$K_{CG} = \sqrt{\frac{M\left(\frac{L^2}{12} + \left(\frac{L}{2} - h_1\right)^2\right) + m(Y_1 - h_1)^2}{M + m}} \quad (11)$$

Note that:

$$L = h_1 + h_2 = Y_1 + Y_2$$

V- Experimental Procedures:

Part One- Centre Of Percussion:

- 1- Adjust the slide-able mass at any position on the block, and record the distance Y from the mass centre to the pivot point A .
- 2- Take the whole pendulum to the edge of the bench, and balance it as possible to determine the position of the centre of gravity CG , and record the distance h .
- 3- Hang the pendulum on the main frame in a vertical configuration, then give it a small pulse and leave it to oscillate freely.
- 4- Record the time required to complete ten oscillations T .
- 5- From eqns-4 & 5, find the corresponding value of K_A , and then find the equivalent length of the pendulum l_{equ} .
- 6- Put the knife of the compound pendulum on the flat part of the main frame, and use another pendulum with a slidable ball by adjusting the ball at distance equals to l_{equ} from its pivot point. Rise the last pendulum significantly then release it to hit the compound pendulum.

* This point where the impulsive force is applied (*at distance = l_{equ}*) represents the position of the centre of percussion of the pendulum, and you are to verify this by noticing that the knife of the compound pendulum will not slide on the main frame due to this impact; which implies that no reaction is formed at point A .

(*Note: This may be recognised and differentiated better by sticking the compound pendulum at other points*).

- 7- Repeat the previous steps for another four positions of the slideable mass Y .

Part Two- Reversible Pendulum:

- 1- Hang the pendulum from one of its ends A_1 , and adjust the slide-able mass m at any distance from that end Y_1 .
- 2- Displace the pendulum by a small amount, and leave it to oscillate in the vertical plane. Take the time required to complete ten oscillations T_1 .
- 3- Reverse the pendulum (*hang it from the other end A_2*), and measure the distance Y_2 .
- 4- Repeat step-2, and record the time required for another ten oscillations T_2 .
- 5- Repeat the process for total seven different trials.

VI- Collected Data:

Part One- Centre Of Percussion:

Table-2.1 Collected data for the Centre of Percussion part

<i>Trial</i>	<i>Y (cm)</i>	<i>h (cm)</i>	<i>T (second)</i>
<i>1</i>			
<i>2</i>			
<i>3</i>			
<i>4</i>			
<i>5</i>			

Part Two- Reversible Pendulum:

L = (m)

Table-2.2 Collected data for the Reversible Pendulum part

<i>Trial</i>	<i>Y₁ (cm)</i>	<i>T₁ (second)</i>	<i>Y₂ (cm)</i>	<i>T₂ (second)</i>
<i>1</i>				
<i>2</i>				
<i>3</i>				
<i>4</i>				
<i>5</i>				
<i>6</i>				
<i>7</i>				

VII- Data Processing:

Part One- Centre Of Percussion:

From eqn-5: $\tau = 2\pi \sqrt{\frac{K_A^2}{gh}}$	Find K_A .
From eqn-6: $l_{equ} = \frac{K_A^2}{h} = h + \frac{K_{CG}^2}{h}$	Find l_{equ}

Part Two- Reversible Pendulum:

From eqns-8, 9 & 10.	Find h_1 , h_2 , and K_{CG} respectively.
From eqns-7 & 8: $\tau_1 = 2\pi \sqrt{\frac{K_{A1}^2}{gh_1}} = 2\pi \sqrt{\frac{K_{CG}^2 + h_1^2}{gh_1}}$ $\tau_2 = 2\pi \sqrt{\frac{K_{A2}^2}{gh_2}} = 2\pi \sqrt{\frac{K_{CG}^2 + h_2^2}{gh_2}}$	Use each one separately to find the value of the gravitational acceleration g . Compare the results with the standard value.
Use eqns-7 & 8, with the standard value of g .	Evaluate the theoretical period of oscillation $\tau_{1-Theor}$ from eqn-7, and compare it with the experimental value $\tau_{1-Exper}$. For eqn-8, find $\tau_{2-Theor}$ and compare it to $\tau_{2-Exper}$.
Equate both eqns-7 & 8, to get: $\frac{K_{CG}^2 + h_1^2}{h_1} = \frac{K_{CG}^2 + h_2^2}{h_2}$	To find h_1 , h_2 corresponding to same period: Draw τ_1 , τ_2 versus h_1 as shown in Figure-2.3, then the point of intersection represents h_1 corresponding to $(\tau_1 = \tau_2)$. And from h_1 you can find h_2 , Y_1 and Y_2 .

VIII- Results:

Part One- Centre Of Percussion:

Table-2.3 Data processing results for the Centre of Percussion part

Trial	Y (cm)	h (cm)	τ (second)	K_A (cm)	l_{equ} (cm)
1					
2					
3					
4					
5					

Part Two- Reversible Pendulum:

Table-2.4 Data processing analysis for the reversible pendulum part

Trial	Y_1 (cm)	Y_2 (cm)	h_1 (cm)	h_2 (cm)	K_{CG} (cm)
1					
2					
3					
4					
5					
6					
7					

Table-2.5 Data processing results for the Reversible Pendulum part

Trial	τ_1-Theor. (second)	τ_1-Exper. (second)	τ_1 Percent Error (%)	τ_2-Theor. (second)	τ_2-Exper. (second)	τ_2 Percent Error (%)
1						
2						
3						
4						
5						
6						
7						

Table-2.6 Data processing results for the Reversible Pendulum part

<i>Trial</i>	<i>g eqn-7 (m/sec.²)</i>	<i>g Percent Error (%)</i>	<i>g eqn-8 (m/sec.²)</i>	<i>g Percent Error (%)</i>
<i>1</i>				
<i>2</i>				
<i>3</i>				
<i>4</i>				
<i>5</i>				
<i>6</i>				
<i>7</i>				

Table-2.7 Data processing results for the Reversible Pendulum part

<i>From Figure-2.3:</i>			
<i>h₁ (cm)</i>		<i>h₂ (cm)</i>	
<i>Y₁ (cm)</i>		<i>Y₂ (cm)</i>	

IX- Discussion And Conclusions:

- 1) What is the physical meaning of the equivalent length of the compound pendulum?

- 2) One of the important employments of the concept of the centre of percussion in engineering is found in the automobile, by the proper selection of the positions of the front and rear axles relative to each other, how would you explain that?

- 3) Comment on your observations concerning the reaction at the pivot point of the compound pendulum, when it has been hit at its centre of percussion compared to other points?

- 4) Name the major sources of errors in the experiment, and comment briefly on the effect of each one on the results obtained?

- 5) In the reversible pendulum part of the experiment, the effect of the knives fixed at both ends of the bar has not been Considered in the determination of h_1 , h_2 & K_{CG} . Consider any case from *Table-2.2*, and recalculate the corresponding parameters with these knives included, and find the resulted error for each parameter? (*The mass of each knife is $M_K = 0.21$ kg*).

Bifilar Suspension & Auxiliary Mass Method

I- Introduction:

The Bifilar Suspension is a technique that could be applied to objects of different shapes, but capable to be suspended by two parallel equal-length cables, in order to evaluate its mass moment of inertia I about any point within the body. In this experiment, the technique will be applied to find the mass moment of inertia of a regular cross-section steel beam about its centre of gravity.

II- Objectives:

This experiment is to be performed in order to evaluate the mass moment of inertia of a prismatic beam by introducing two methods:

- 1) The Bifilar Suspension Technique.
- 2) The Auxiliary Mass Method.

Then the values obtained from the two different methods will be compared with the value obtained analytically, using the geometry and dimensions of the beam.

III- System Description:

The layout of the experiment is shown schematically in *Figure-3.1*, in which we have a regular rectangular cross-section steel beam, of length L , total mass M , and mass moment of inertia about its centre of gravity I . The beam is suspended horizontally through two vertical chords, each of length l , and at distance $b/2$ from the middle of the beam CG .

(Two small chucks are provided for attachment).

The system is initially balanced, and by exerting a small pulse in such a way that the beam keeps oscillating in the horizontal plane about its middle point (*centre of gravity CG*), then by virtue of the tension forces initiated in the suspension chords, the beam will oscillate making an angle θ with its neutral axis, and the suspension chords will make an angle ϕ with the original vertical position. *(General view of the system is shown in Figure-3.2).*

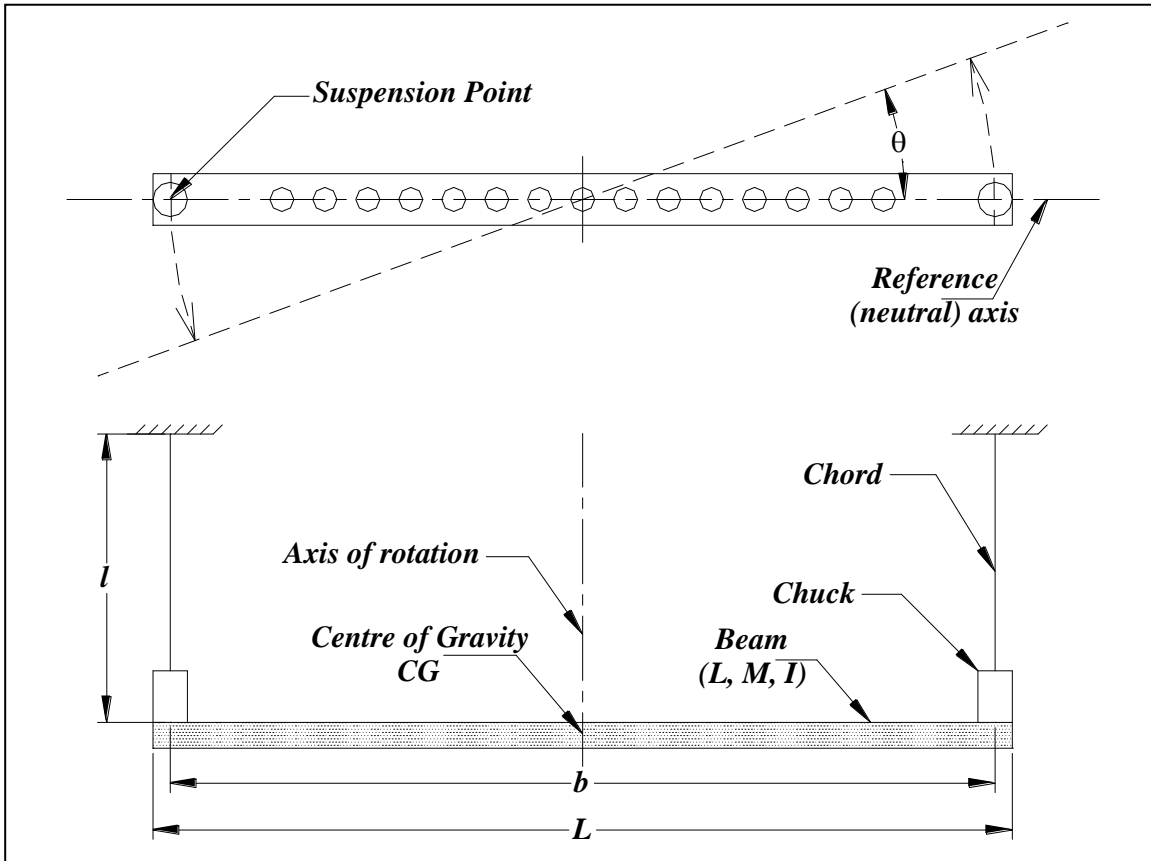

Figure-3.1 General layout of the Bifilar Suspension

IV- Governing Equations:

Part One- Bifilar Suspension Technique:

In the system shown in *Figures-3.1 & 2*, and under equilibrium conditions, the tension force in each chord is equal to $Mg/2$, and by disturbing the system with an initial angular displacement Θ about the middle point in the horizontal plane, it will oscillate with a time-varying angle $\theta(t)$ under the action of the tension forces in the chords.

Taking the summation of moments about the middle point (*Centre of Gravity CG*), we get the equation of motion as:

$$I\ddot{\theta} + \left(\frac{Mgb}{2}\right)\phi = 0 \tag{1}$$

But:

$$\frac{b}{2}\theta = l\phi \quad (\text{By equating the length of the arc of oscillation})$$

Substituting in eqn-1, and rearranging:

$$\Rightarrow \ddot{\theta} + \left(\frac{Mgb^2}{4Il} \right) \theta = 0 \quad (2)$$

From the above equation of motion, we find that:

$$* \text{ Natural frequency} = \omega_n = \sqrt{\frac{Mgb^2}{4Il}} \quad (3)$$

$$* \text{ Period of oscillation} = \tau = \frac{2\pi}{\omega_n} = 2\pi \sqrt{\frac{4Il}{Mgb^2}} \quad (4)$$

Part Two- Auxiliary Mass Method:

Consider the previous system with the addition of two identical circular disks of radius R , mass m , and inertia I_m ; each at a side at distance Y from the middle of the beam.

The resulting equation of motion of the modified system will be:

$$(I + 2I_m)\ddot{\theta} + \left(\frac{(M+2m)gb^2}{4l} \right) \theta = 0 \quad (5)$$

where;

$$I_m = m(R^2 + Y^2), \quad m = \rho\pi R^2 h_m$$

Rearrange eqn-5, yields:

$$\ddot{\theta} + \left(\frac{(M+2m)gb^2}{4l(I+2I_m)} \right) \theta = 0 \quad (6)$$

From eqn-6, the natural frequency and the period of oscillation are found as:

$$* \text{ Natural frequency} = \omega_n = \sqrt{\frac{gb^2(M+2m)}{4l(I+2I_m)}} \quad (7)$$

$$* \text{ Period of oscillation} = \tau = \frac{2\pi}{\omega_n} = 2\pi \sqrt{\frac{4l(I+2I_m)}{gb^2(M+2m)}} \quad (8)$$

Part Three- Analytical Solution:

Using the dimensions of the beam, then its mass moment of inertia about the centre of gravity can be found analytically as follows:

$$I = I(\text{solid beam}) - I(\text{holes}) + I(\text{two chucks}) \\ = I_s - I_H + I_C \quad (9)$$

$$1) I_s = \frac{M_s L^2}{12} = \frac{\rho whL^3}{12} \quad (10)$$

$$2) I_H = \frac{15}{2} M_H r^2 + 2M_H \sum X^2 \\ = \rho\pi r^2 h \left(\frac{15}{2} r^2 + 2 \sum X^2 \right) \quad (11)$$

as:-

r : the radius of each hole.

X : the distance between the hole and the middle point of the beam.

$$3) I_C = M_c r_c^2 + 2M_c \left(\frac{b}{2} \right)^2 \\ = \rho\pi r_c^2 h_c \left(r_c^2 + \frac{b^2}{2} \right) \quad (12)$$

as:-

r_c : the radius of the chuck.

h_c : the height of the chuck.

The geometry and the definitions of the basic parameters of the system are provided in *Figure-3.2*.

V- Experimental Procedures:

Part One- Bifilar Suspension Technique:

- 1- Attach the first chord to the main frame and measure its length, then attach the second chord to the main frame with the same length as the first one.
(The length to be measured and included in the calculations l should include both the chord's length and the chuck's height, see Figure-3.1)
- 2- Insert a slender rod through the middle hole of the beam, to provide as an axis of rotation for the beam.
- 3- Hold the slender rod in place and give the beam a small displacement from one of its ends in the transverse direction. The beam should oscillate in the horizontal plane only.
- 4- Measure the time elapsed to complete ten oscillations T .
- 5- Release the chords then re-attach them at another length l , and repeat steps-2, 3 & 4.
- 6- Repeat step-5 four more times to get total six pairs of l and T .

Part Two- Auxiliary Mass Method:

- 1- Take the previous system and fix it at any length l .
- 2- Put the two disks (*auxiliary masses*) at distance Y from the beam's middle point, each at a side, and record the value of Y .
- 3- Displace the beam slightly as in the previous part, and again measure the time elapsed in ten oscillations T .
- 4- Change the positions of the two masses to new value of Y , then repeat step-3.
- 5- Repeat step-4 for total different six values of Y .

VI- Collected Data:

Basic Parameters:

Table-3.1 Dimensions to be used according to Figures-3.1 & 2

<i>Parameter</i>	<i>Value</i>	<i>Parameter</i>	<i>Value</i>
<i>L (cm)</i>		<i>r_c (mm)</i>	
<i>w (mm)</i>		<i>h_c (mm)</i>	
<i>h (mm)</i>		<i>R (mm)</i>	
<i>b (mm)</i>		<i>h_m (mm)</i>	
<i>r (mm)</i>			

Part One- Bifilar Suspension Technique:

Table-3.2 Data collected for the Bifilar Suspension Technique part

<i>Trial</i>	<i>l (cm)</i>	<i>T (second)</i>
<i>1</i>		
<i>2</i>		
<i>3</i>		
<i>4</i>		
<i>5</i>		
<i>6</i>		

Part Two- Auxiliary Mass Method:

l =(cm)

m =(kg)

Table-3.3 Data collected for the Auxiliary Mass Method part

<i>Trial</i>	<i>Y (cm)</i>	<i>T (second)</i>
<i>1</i>		
<i>2</i>		
<i>3</i>		
<i>4</i>		
<i>5</i>		
<i>6</i>		

VII- Data Processing:

Part One- Bifilar Suspension Technique:

Square eqn-4 to get: $\tau^2 = \left(\frac{16\pi^2 I}{Mgb^2} \right) l$	Draw τ^2 versus l as shown in <i>Figure-3.3</i> .	Slope = $\frac{16\pi^2 I}{Mgb^2}$ $\Rightarrow I$ is determined.
---	--	---

Part Two- Auxiliary Mass Method:

Square eqn-8 to get: $\tau^2 = \frac{16\pi^2 l(I + 2I_m)}{gb^2(M + 2m)}$	Draw τ^2 versus I_m as shown in <i>Figure-3.4</i> .	1- Slope = $\frac{32\pi^2 l}{gb^2(M + 2m)}$ \Rightarrow Determine g and compare it with the standard value. 2- Interception with the vertical axis $Y_{int} = \frac{16\pi^2 I l}{gb^2(M + 2m)}$ $\Rightarrow I$ is determined. 3- Interception with the horizontal axis $X_{int} = -\frac{I}{2}$ $\Rightarrow I$ is verified.
---	--	--

VIII- Results:

Part One- Bifilar Suspension Technique:

$M = \dots\dots\dots$ (kg).

Table-3.4 Data processing analysis for the Bifilar Suspension Technique part

Trial	l (cm)	τ (second)	τ^2 (second²)
1			
2			
3			
4			
5			
6			

Table-3.5 Data processing results for the Bifilar Suspension Technique part

Quantity	Slope (sec.²/m)	I (kg.m²)
From Figure-3.3		

Part Two- Auxiliary Mass Method:

Table-3.6 Data processing analysis for the Auxiliary Mass Method part

Trial	Y (cm)	I_m (kg.m²)	τ^2 (second²)
1			
2			
3			
4			
5			
6			

Table-3.7 Data processing results for the Auxiliary Mass Method part

From Figure-3.4			
Slope (s²/m².kg)		g (m/sec.²)	
Y_{Int} (sec.²)		I (kg.m²)	
X_{Int} (kg.m²)		I (kg.m²)	

Part Three- Analytical Solution:

Table-3.8 Analytical determination of the mass moment of inertia I

I_S (kg.m²)	
I_H (kg.m²)	
I_C (kg.m²)	
$I = I_S - I_H + I_C$ (kg.m²)	

Comparison:

Table-3.9 Comparison of I obtained by the two methods with the analytical value

Method:	I (kg.m²)	Percentage Error (%)
Analytically		
Bifilar Suspension		
Auxiliary Mass		

IX- Discussion And Conclusions:

- 1) In the first part, what modifications should be done (*concerning the derivation of equation of motion*) in order to determine the mass moment of inertia about any point other than the middle point of the beam? Derive the equation of motion for this case.

- 2) In the second part (*the Auxiliary Mass Method part*), is it acceptable to use only one mass at either sides of the beam? Explain?

- 3) Referring to the derivation of the equation of motion for the beam, why is it important to keep the angle of oscillation of the beam small during the execution of the experiment? What is the basic assumption that is based on assuming a small angle of oscillation?

- 4) From your results, comment on the accuracy of the two methods, mentioning the major sources of errors in each part of the experiment?

Rotor (Flywheel) Systems

I- Objectives:

This experiment consists of three major parts dealing with various items concerning rotor systems, and the general features and objectives to be recognised of each part are as follows:

- 1- The first part provides the procedures for determining the mass moment of inertia I of two rotors (*Flywheels*) of different sizes, using the *Accelerating Torque Method*. The results of this method are to be compared with the analytical values obtained from the given dimensions of the two rotors.
- 2- In the second part, time measurements are used to estimate the modulus of rigidity G of a slender steel shaft, which is to be compared with the standard value for steel (*about 80 GPa*).
- 3- The third part is simply a two-rotors' system, presented to study the response (*behaviour*) of such a system under vibrations, and use it to:
 - Find the period of oscillation of the system at a certain length of the connecting shaft, to be compared with the theoretical value.
 - Determine the position of the nodal point of the system both experimentally and analytically.

II- System Description:

Part One- Rotor's Inertia Determination:

The schematic representation of this part is shown in *Figure-4.1*, in which the circular rotor of mass M , radius R and mass moment of inertia I ; is fitted to the main frame by a bearing joint, with freedom of rotation about its central axis.

A small mass ($m = 20 \text{ gm}$) is attached to one end of a chord, while the last is wound around the circumference of the circular rotor, and the whole assembly is held in place with the small mass at elevation h from the floor.

When the mass is released, it moves downward with acceleration a , causing the flywheel (*rotor*) to rotate with angular acceleration α , by virtue of the tension force T established in the chord. Travelling distance h from the instance of

releasing the small mass so that it reaches the floor takes place in the time interval t .

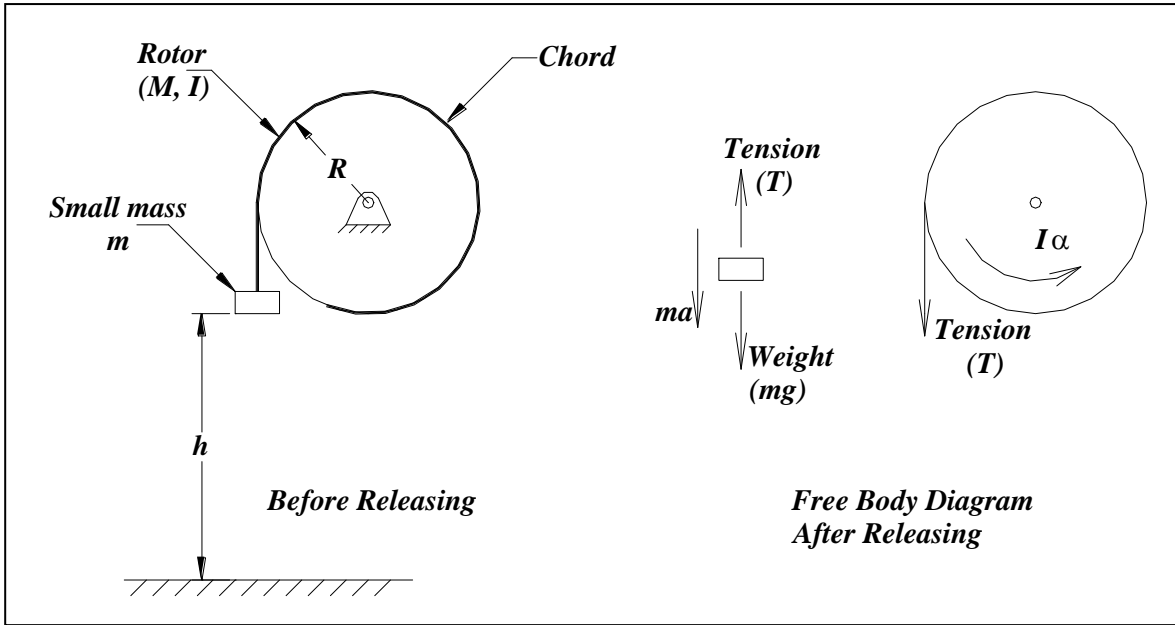

Figure-4.1 Layout of the Rotor's Inertia Determination part

Part Two- Modulus Of Rigidity Determination:

The system described in *Figure-4.2* below is simply a circular disk of mass M and mass moment of inertia I , fitted to the main frame by a bearing joint as in the previous part but attached to the end of a slender circular shaft of length L , diameter d , polar moment of inertia J and modulus of rigidity G . The other end of the shaft is fixed.

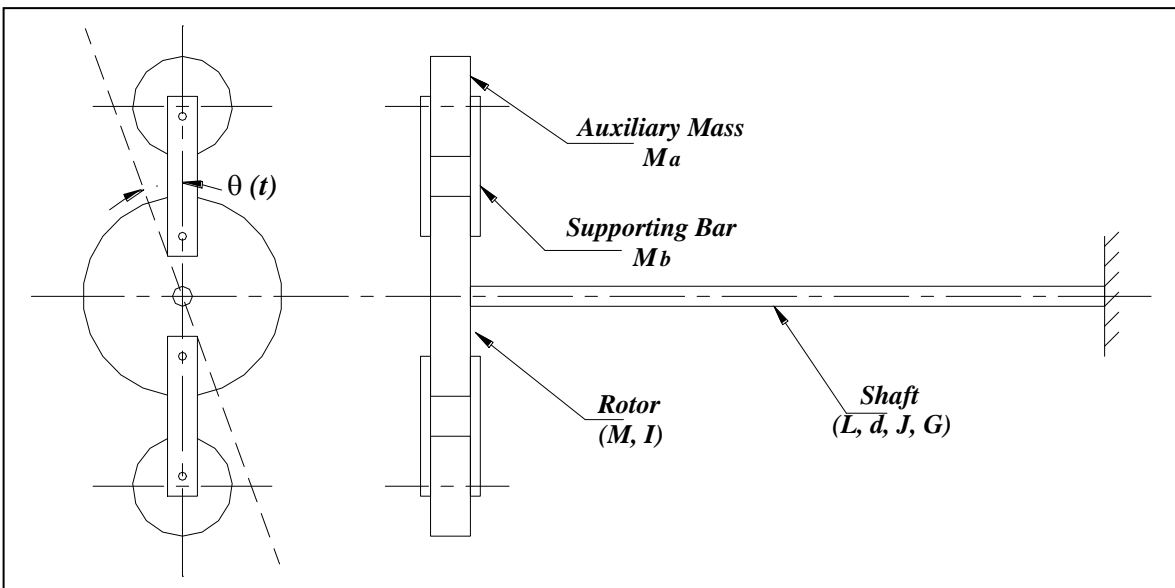

Figure-4.2 Layout of the Modulus of Rigidity Determination part

Two small auxiliary masses ($M_a = 1.80 \text{ kg}$) are added to the rotor by means of two supporting bars, each of mass ($M_b = 0.350 \text{ kg}$). The whole assembly oscillates about the axis of the shaft with a time varying angle $\theta(t)$, as a result of an initial angular displacement Θ .

Part Three- Two-Rotors' System:

The system shown in Figure-4.3 consists of two flywheels of different sizes; big rotor (*Rotor-1*) of mass M_1 and inertia I_1 , and a small rotor (*Rotor-2*) with mass and inertia M_2 and I_2 , respectively. The two rotors are attached to the ends of a slender shaft of length L , diameter d , polar moment of inertia J and modulus of rigidity G .

Giving one of them an initial angular displacement Θ with respect to the other one, the two rotors will oscillate in their own planes with opposite sense to each other, by the angles $\theta_1(t)$ and $\theta_2(t)$, respectively.

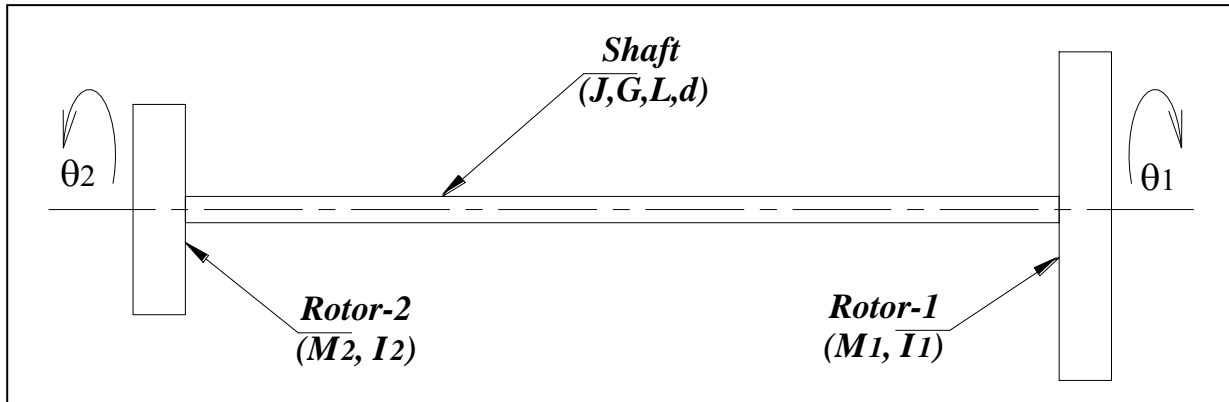

Figure-4.3 Layout of the Two-Rotors' System part

III- Governing Equations:

Part One- Rotor's Inertia Determination:

From the free body diagrams of the rotor and the small mass in *Figure-4.1*, then by assuming a frictionless bearing (*negligible friction*), then the equation of motion of the rotor is given by:

$$I\ddot{\theta} - TR = 0 \quad (1)$$

But,

$$\begin{aligned} \ddot{\theta} &= \alpha = \frac{a}{R} \\ \Rightarrow \frac{Ia}{R} - TR &= 0 \end{aligned} \quad (2)$$

For the small mass, by applying *Newton's Second Law* of motion, we get:

$$mg - T = ma \quad (3)$$

Eliminating T from eqns-2 & 3 yields:

$$I = mR^2 \left(\frac{g}{a} - 1 \right) \quad (4)$$

Provided that the rotor is supported on a frictionless bearing, we may approximate the acceleration of the small mass by *Newton's Law* of free falling:

$$h \approx 0.5at^2$$

By substitution in eqn-4, we end up with:

$$I = mR^2 \left(\frac{gt^2}{2h} - 1 \right) \quad (5)$$

Theoretically:

For a circular disk, the mass moment of inertia is given by the formula:

$$I = \frac{1}{2} MR^2$$

And for the general case shown in *Figure-4.4*, a generalized form of this equation can be written as:

$$I = \sum \frac{1}{2} MiRi^2 \quad (6)$$

Part Two- Modulus Of Rigidity Determination:

For the system shown in *Figure-4.2*, and with the aid of *Figure-4.4*, then:

The equation of motion of the assembly is:

$$I_T \ddot{\theta} + K_T \theta = 0 \quad (7)$$

From this, the natural frequency and the period of oscillation are found to be:

$$* \text{ Natural frequency} = \omega_n = \sqrt{\frac{K_T}{I_T}} \quad (8)$$

$$* \text{ Period of oscillation} = \tau = \frac{2\pi}{\omega_n} = 2\pi \sqrt{\frac{I_T}{K_T}} \quad (9)$$

where:

I_T : is the total inertia of the whole assembly

$$I_T = I + I_a + I_b \quad (10)$$

$$I_a = 2M_a \left(\frac{r^2}{2} + C_1^2 \right) \quad (11)$$

$$I_b = 4M_b \left(\frac{b^2}{12} + C_2^2 \right) \quad (12)$$

K_T : is the torsion stiffness of the shaft, and it is given by:

$$K_T = \frac{GJ}{L} = \frac{\pi G d^4}{32L} \quad (13)$$

Part Three- Two-Rotors' System:

Referring to the system shown in *Figure-4.3*, then:
The equation of motion of *Rotor-1* is:

$$\begin{aligned} I_1 \ddot{\theta}_1 + K_T (\theta_1 - \theta_2) &= 0 \\ \Rightarrow \ddot{\theta}_1 + \frac{K_T}{I_1} (\theta_1 - \theta_2) &= 0 \end{aligned} \quad (14)$$

The equation of motion of *Rotor-2* is:

$$\begin{aligned} I_2 \ddot{\theta}_2 + K_T (\theta_2 - \theta_1) &= 0 \\ \Rightarrow \ddot{\theta}_2 + \frac{K_T}{I_2} (\theta_2 - \theta_1) &= 0 \end{aligned} \quad (15)$$

Define ϕ as the relative angular displacement between the two rotors, that is:

$$\phi = (\theta_1 - \theta_2)$$

Subtract *eqn-15* from *eqn-14*, and substitute $(\ddot{\theta}_1 - \ddot{\theta}_2 = \ddot{\phi})$ to get:

$$\ddot{\phi} + K_T \left(\frac{I_1 + I_2}{I_1 I_2} \right) \phi = 0 \quad (16)$$

From which we end up with:

$$* \text{Natural frequency} = \omega_n = \sqrt{\frac{K_T (I_1 + I_2)}{I_1 I_2}} \quad (17)$$

$$* \text{Period of oscillation} = \tau = \frac{2\pi}{\omega_n} = 2\pi \sqrt{\frac{I_1 I_2}{K_T (I_1 + I_2)}} \quad (18)$$

Nodal Point:

During the oscillation of the system; each rotor rotates in the opposite sense of the other one, and the amplitude of the angular rotation of the shaft starts its maximum value at each end, and decreases as moving far a way from that one due to the influence of the rotor on the other end. As a result of this, a point along the shaft will experience no rotation where each rotor cancels out the effect of the other one; this point is called the *Nodal Point*.

This system is equivalent to a similar one in which a fixed wall is positioned at the nodal point, while the two rotors oscillate separately with equal periods of oscillation, rotor-1 with a shaft of length L_1 , and rotor-2 with a shaft of length L_2 .

Mathematically:

$$\begin{aligned} \tau_1 &= \tau_2 \\ \Rightarrow 2\pi \sqrt{\frac{I_1 L_1}{GJ}} &= 2\pi \sqrt{\frac{I_2 L_2}{GJ}} \end{aligned}$$

But:

$$L = L_1 + L_2,$$

$$\Rightarrow L_1 = \frac{I_2}{I_1 + I_2} L, \quad L_2 = \frac{I_1}{I_1 + I_2} L \quad (19)$$

IV- Experimental Procedures:

Part One- Rotor's Inertia Determination:

- 1- Fix one of the rotors to the main frame with its axis of rotation in the horizontal direction, and the rotor is free to rotate about it.
- 2- Wind the cord around the circumference of the rotor, and attach the small mass m to its tip. Hold the rotor in place, and measure the height of the small mass from the ground h .
- 3- Release the rotor, and allow the mass to fall freely until reaching the floor. Record the elapsed time t .
- 4- Repeat the same steps using the other rotor.

Part Two- Modulus Of Rigidity Determination:

- 1- Start with the same configuration of the previous part using one of the rotors, and use the steel shaft by fitting one of its ends to the rotor, and the other end to the main frame at any length L , then record that length.
- 2- Add the two Auxiliary masses (*Rotors*) at both sides of the rotor, with the aid of four rectangular bars as demonstrated in *Figures-4.2 & 4.4*.
- 3- Twist the rotor gently then release it to oscillate freely, and record the time elapsed to complete ten oscillations T .
- 4- Change the length of the shaft L , and repeat steps-2 & 3.
- 5- Repeat step-4 another six times to get total eight pairs of L and T .
- 6- Do the same with the other rotor in place of first one.

Part Three- Two-Rotors' System:

- 1- Take the two rotors and fix each close to one end of the shaft, and measure the distance between them L .
(Use a long distance for better observations).
- 2- Make a line of chalk along the shaft.
- 3- Hold the two rotors at a time, and twist them in opposite sense to each other.
- 4- Release them, then measure and record the time elapsed in ten oscillations T .

- 5- Try to identify the nodal point with the aid of the line being established, and determine its position with respect to the two rotors; record L_1 & L_2 .

V- Collected Data:

Part One- Rotor's Inertia Determination:

Table-4.1 Data collected for the Rotor's Inertia Determination part

Rotor	h (cm)	t (second)
Rotor-1		
Rotor-2		

Part Two- Modulus Of Rigidity Determination:

Table-4.2 Data collected for the Modulus of Rigidity Determination part

Trial	Rotor-1		Rotor-2	
	L (cm)	T (second)	L (cm)	T (second)
1				
2				
3				
4				
5				
6				
7				
8				

Part Three- Two-Rotors' System:

Table-4.3 Data collected for the Two-Rotors' System part

Parameter	L (cm)	T (second)
Value		

Basic Parameters And Dimensions:

Table-4.4 Dimensions of the two rotors according to Figure-4.4

<i>Dimension</i>	<i>Rotor-1</i>	<i>Rotor-2</i>	<i>Dimension</i>	<i>Rotor-1</i>	<i>Rotor-2</i>
<i>R₁ (mm)</i>			<i>R₂ (mm)</i>		
<i>R₃ (mm)</i>			<i>R₄ (mm)</i>		
<i>t₁ (mm)</i>			<i>t₂ (mm)</i>		
<i>t₃ (mm)</i>			<i>t₄ (mm)</i>		

Table-4.5 Basic parameters of the two rotors shown in Figure-4.4

<i>Parameter</i>	<i>Value</i>	<i>Parameter</i>	<i>Value</i>
<i>C₁ (mm)</i>		<i>C₂ (mm)</i>	
<i>r (mm)</i>		<i>b (mm)</i>	
<i>d (mm)</i>			

VI- Data Processing:

Part One- Rotor's Inertia Determination:

Apply in eqn-5: $I = mR^2 \left(\frac{gt^2}{2h} - 1 \right)$	Evaluate I_1 of rotor-1, and I_2 of rotor-2.
From the geometry of the two rotors, and with the dimensions provided and shown in Figure-4.4 and Table-4.4. Use eqn-6: $I = \sum MiRi^2$	Find I_1 and I_2 , and compare the results with the experimentally obtained values.

Part Two- Modulus Of Rigidity Determination:

From the dimensions available in <i>Table-4.5</i> , and using <i>eqns-11, 12 & 13</i> .	Evaluate I_a, I_b, J and K_T	Determine I_T from <i>eqn-10</i>
Square <i>eqn-9</i> , to get: $\tau = 4\pi^2 \frac{I_T}{K_T} = 4\pi^2 \frac{I_T L}{GJ}$	Draw τ^2 versus L	Slope = $\frac{4\pi^2 I_T}{GJ}$ \Rightarrow Find G , and compare it with the standard value.

Part Three- Two-Rotors' System:

Use <i>eqn-18</i> : $\tau = \frac{2\pi}{\omega_n} = 2\pi \sqrt{\frac{I_1 I_2}{K_T (I_1 + I_2)}}$	Evaluate τ .	Compare it with the experimentally obtained value.
From <i>eqn-19</i> : $L_1 = \frac{I_2}{I_1 + I_2} L$ $L_2 = \frac{I_1}{I_1 + I_2} L$	Determine the value of L_1, L_2 .	Compare these values to those estimated from the observation of the nodal point experimentally.

VII- Results:

Part One- Rotor's Inertia Determination:

Table-4.6 Data processing results for the Rotor's Inertia Determination part

Rotor	I (kg.m²) [Eqn-5]	I (kg.m²) [Analytically]	Percent Error (%)
Rotor-1			
Rotor-2			

Part Two- Modulus Of Rigidity Determination:

Table-4.7 Data processing analysis for the Modulus of Rigidity Determination part

Parameter	Value
I_a (kg.m²)	
I_b (kg.m²)	
J (m⁴)	
K_T (N.m/rad)	

Table-4.8 Data processing analysis for the Modulus of Rigidity Determination part

Rotor-1, $I_T = \dots\dots\dots$(kg.m²)			
Trial	L (cm)	τ (second)	τ^2 (second²)
1			
2			
3			
4			
5			
6			
7			
8			

Table-4.9 Data processing analysis for the Modulus of Rigidity Determination part

Rotor-2, $I_T = \dots\dots\dots(kg.m^2)$			
Trial	L (cm)	τ (second)	τ^2 (second²)
1			
2			
3			
4			
5			
6			
7			
8			

Table-4.9 Data processing results for the Modulus of Rigidity Determination part

Rotor	Slope (kg/N)	G (Gpa)	Percent Error (%)
Rotor-1			
Rotor-2			

Part Three- Two-Rotors' System:

Table-4.10 Data processing results for the Two-Rotors' System part

Parameter	Theoretically	Experimentally	Percent Error (%)
τ (second)			
L_1 (cm)			
L_2 (cm)			

Forced Vibrations with Negligible Damping

I- Introduction:

Forced Vibrations is that mode of vibrations in which the system vibrates under the action of a time-varying force, generally; a harmonic external excitation of the form: $f(t) = F \sin(\omega t)$.

The importance of this mode rises in the practical field, as machines, motors and other industrial applications, exhibits this mode of vibrations, which may cause a serious damage of the machine.

II- Objectives:

In this experiment, we will apply both modes of vibrations; free and forced modes of vibrations, on a system in order to:

1- Evaluate of the natural frequency of the system using the following methods:

- 1) Equation of motion.
- 2) Time measurements.
- 3) Drum speed.
- 4) Resonance observation.

And the results of the various methods will be compared with the analytical value from the equation of motion.

2- Study the response of the system under the action of a time-varying force, then to determine and compare the magnification factor obtained both theoretically and experimentally.

III- System Description:

The system to be used in the experiment is shown in *Figure-5.1*, which consists of a regular rectangular cross-section beam of mass M_b , length L , width w and thickness t ; pinned at one end to the main frame at point O , where it is free to

rotate about, and suspended from point S by a linear helical spring of stiffness K at distance b from point O .

A motor with mass ($M = 4.55 \text{ kg}$) is fitted on the beam at distance a from pivot point O , and drives two circular discs with total eccentric mass m at distance e from the centre of the disc (*The eccentric mass is obtained from a hole in each disk with radius r and thickness t_d*). When the motor rotates these discs with speed ω , a harmonic excitation is established on the beam, and as a result of that, the beam vibrates in the vertical plane with angle $\theta(t)$ measured from the horizontal reference direction.

The free end of the beam carries a pencil that touches a rotating cylinder (*drum*) with a strip of paper covering it, so that you can draw the vibrations of the beam for a given period of time.

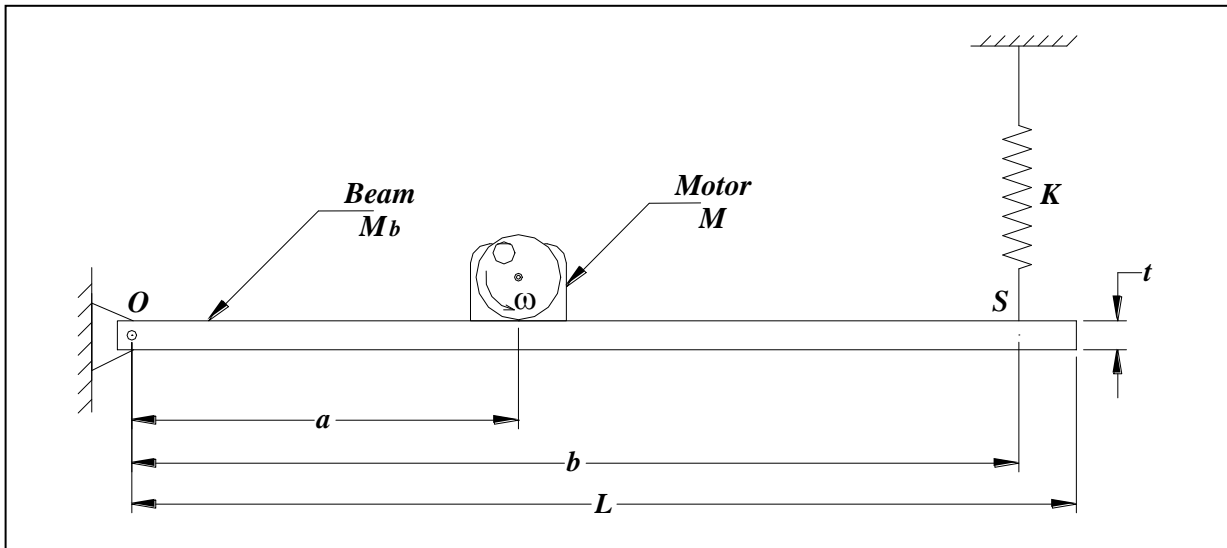

Figure-5.1 General layout of the experiment set-up

IV- Governing Equations:

Part One- Free Vibrations:

- 1) Referring to the system shown in *Figure-5.1*, with the motor is not operated; by giving the system an initial displacement and then leaving it to oscillate freely, the system will exhibit a free mode of vibrations, and the equation of motion in such case is obtained by taking the summation of moments about point O as follows:

$$I\ddot{\theta} + Kb^2\theta = 0 \quad (1)$$

From which the natural frequency is found to be:

$$\omega_n = \sqrt{\frac{Kb^2}{I}} \quad (2)$$

where:-

$$I = \left(Ma^2 + M_b \frac{L^2}{3} \right) \quad (3)$$

$$K = \frac{Gd^4}{8ND^3} \quad (\text{For a helical spring}) \quad (4)$$

2) Also from time measurements, the natural frequency is equal to:

$$\omega_n = \frac{2\pi}{\tau} \quad (5)$$

3) Doing the same as in (1), in addition to getting the drum in touch with the pencil at the end of the beam, a graph of the oscillations of the beam can be obtained by rotating the drum. And so, we can say that:

$$\tau = \frac{C}{V} \quad (6)$$

where:-

C is the distance travelled per cycle.

V is the circumferential velocity of the drum.

And again, the natural frequency is obtained from *eqn-5*.

Part Two- Forced Vibrations:

When the motor is in operation, the beam will be imposed to a harmonic excitation due to the eccentric mass in each disk. This harmonic excitation will have the form:

$$f(t) = F \sin(\omega t) = me \omega^2 \sin(\omega t) \quad (7)$$

In this case, the equation of motion of the system is altered by:

$$I\ddot{\theta} + Kb^2\theta = ame\omega^2 \sin(\omega t) \quad (8)$$

Let $\theta(t) = \Theta \sin(\omega t)$, then the solution of the differential equation in (8) gives the amplitude of the angular displacement of the beam Θ as:

$$\Theta = \frac{mea\omega^2}{Kb^2 - I_A\omega^2} \quad (9)$$

And so, the vertical displacement of the end of the beam Y will be:

$$Y = L\Theta = \frac{meaL\omega^2}{Kb^2 - I_A\omega^2} \quad (10)$$

Magnification Factor:

Magnification Factor MF is the ratio between the dynamic amplitude of oscillation and the static amplitude of the same mode of displacement (*degree of freedom*). And for this case, it is expressed as:

$$MF = \frac{Y_{Dynamic}}{Y_{Static}} \quad (11)$$

where:

$Y_{Dynamic}$, is given by eqn-10 above.

$$Y_{Static} = \frac{meaL\omega^2}{Kb^2} \quad (12)$$

Substitute for $Y_{Dynamic}$ and Y_{Static} in eqn-11, and rearrange to get:

$$MF = \frac{1}{1 - r^2} \quad (13)$$

where:

$r = \frac{\omega}{\omega_n}$ is the frequency ratio.

V- Experimental Procedures:

- 1- Use the system described above while the motor is turned off, and give the beam a small vertical displacement, then release it to oscillate freely for ten oscillations. Record the elapsed time T .
- 2- Bring the drum in slight touch with the pencil at the end of the beam, after attaching the roll of paper to the drum, and then give the beam a small pulse to oscillate freely as before with the drum is held fixed.
- 3- Turn the motor of the drum on, and after ten seconds stop it and remove the chart for using it in the calculations.
- 4- Return to the original system by separating the drum from the pencil, and switch the motor on at a relatively slow speed.
- 5- Increase the speed of the motor slowly and notice the response of the system, and at the same time; try to identify the point at which resonance takes place (*When the largest amplitude of vibrations is noticed*). Record the speed of the motor at that state N_r .
- 6- Attach the paper roll again to the drum, and make the pencil in touch with the drum. Activate the motor and set it to any desired speed (*Choose one that gives an appreciable amplitude of vibrations in the beam*), and record that speed N .
- 7- Rotate the drum again for a while, and take the response curve obtained for the subsequent calculations.

VI- Collected Data:

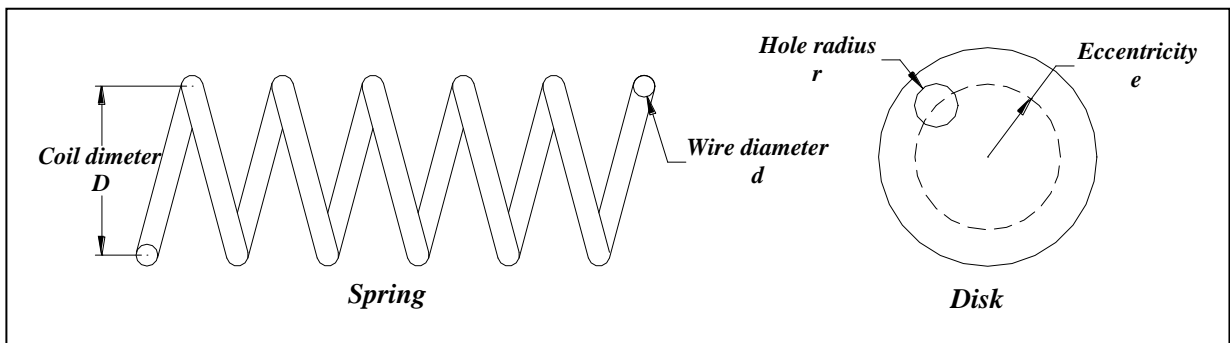

Figure-5.2 Nomenclature of the coil spring and the rotating disc

Basic Parameters And Dimensions:

Table-5.1 Basic dimensions and parameters according to Figures-5.1 & 2

Beam			
Parameter	Value	Parameter	Value
<i>L (cm)</i>		<i>b (cm)</i>	
<i>w (mm)</i>		<i>t (mm)</i>	

Motor, Rotating Disks			
Parameter	Value	Parameter	Value
<i>a (cm)</i>		<i>r (mm)</i>	
<i>e (mm)</i>		<i>t_d (mm)</i>	

Spring			
Parameter	Value	Parameter	Value
<i>D (mm)</i>		<i>d (mm)</i>	
<i>N (turns)</i>			

Table-5.2 Data collected from the experiment

Free Vibrations Part	
Parameter	Value
<i>T (second)</i>	
<i>C [from the first chart] (mm)</i>	
<i>V = C/10 (m/s)</i>	

Forced Vibrations Part	
Parameter	Value
<i>N_r (rpm)</i>	
<i>N (rpm)</i>	
<i>A [amplitude of the second chart] (mm)</i>	

VII- Data Processing:

Part One- Free Vibration:

From the dimensions provided, and using eqns-3 & 4.	Find M_b , I and K .	Apply in eqn-2 to find the theoretical natural frequency $\omega_{n-theor}$
From T find τ , as: $\tau = \frac{T}{10}$	From eqn-5, find ω_n .	Compare it with $\omega_{n-theor}$.
Calculate the velocity of the drum V , and use eqn-6 to find τ .	Apply again in eqn-5 to find ω_n .	Compare it with $\omega_{n-theor}$.

Part Two- Forced Vibration:

For the speed of the motor at resonance Nr , find the equivalent angular frequency of the motor ω .	This frequency will be equal to the natural frequency of the system ω_n .	Compare it with $\omega_{n-theor}$.
From the value of N at which the second chart has been plotted, find the corresponding angular frequency ω .	1) Evaluate the frequency ratio r using $\omega_{n-theor}$, and apply eqn-13 to evaluate MF . 2) From eqn-12, find Y_{Static} , and from the second chart evaluate $Y_{Dynamic}$, then apply in eqn-11 to evaluate MF .	Compare the results of the two ways.

VIII- Results:

Table-5.3 Data processing analysis

Parameter	Value
M_b (kg)	
I (kg.m²)	
K (N/m)	

Table-5.4 Results of the natural frequency by the various methods

Method	Natural Frequency ω_n (rad/sec)	Percent Error (%)
Analytical (E.O.M)		
Time Measurements		
Drum Speed		
Resonance Observation		

Table-5.5 Magnification Factor MF results

Method-1	ω (rad/sec)	r (ω/ω_n)	MF	Percent Error (%)
Method-2	$Y_{dynamic}$ (mm)	Y_{static} (mm)	MF	

IX- Discussion And Conclusions:

- 1) What is the meaning of the Static Amplitude of oscillation? In this case, derive the expression of (Y_{static}) given in eqn-12?

2) Draw the magnification factor MF versus frequency ratio r for the system, for this mode of forced vibrations (*Rotating Unbalance*)?

Draw the expected ideal curve for this case, and another one based on your expectations for the real case, showing the deviations from the ideal one.

3) According to your observations and plot in the previous question, did the amplitude of oscillations reach a very high value at resonance? If not, why?

4) In the derivation of the equation of motion for the system, why did not we consider the effect of the gravitational forces (*weights of its components*) although they have moments about point O ?

5) For a practical system like a machine, suffering from such mode of vibrations, how could you modify its parameters (\uparrow or \downarrow), or add other components, in a way that minimises vibrations level?

Static & Dynamic Balancing

I- Introduction:

Balancing is an essential technique applied to mechanical parts of rotational functionality (*wheels, shafts, flywheels...*), in order to eliminate the detected irregularities found within it, and that may cause excessive vibrations during operation, and act as undesirable disturbances on the system being in use. Such irregularities may rise due to the inhomogeneous distribution of material within the part, bending and deflection of rotating shafts, and eccentricity of mass from the axis of rotation of the rotating disks and rotors.

These irregularities lead to small eccentric masses that disturb mass distribution of the part, and the last generate *centrifugal forces* when the part is in rotation; the magnitude of these forces increases rapidly with speed of rotation, and enhances vibrations level during operation, and cause serious problems.

II- Objectives:

This experiment is established in order to introduce and interpret the general features of balancing technique, in addition to familiarise the student with the basic steps in applying both static and dynamic balancing techniques on unbalanced mechanical parts.

III- Technique Presentation:

Part One- Static Balancing:

Static Balancing simply means the insurance of mass distribution about the axis of rotation of the rotating mechanical part in the radial directions, without consideration of that distribution in the axial (*longitudinal*) direction.

To illustrate this; consider a circular disk of perfect mass distribution, with the points *A* and *B* are at two opposite positions on the circumference of the disk, but each is on one of the faces of the disk, and suppose that a point mass with the same value is fixed at each of the two points *A* and *B*.

Generally, static balancing looks to the part in the direction of its axis of rotation, so in this case, as the two eccentric masses at *A* and *B* are in opposite positions with equal distances from the central axis, the disk is considered statically balanced although these masses are at different axial positions.

Practically, static balancing is performed by taking the part like a disk with its axis of rotation oriented horizontally, and rotating it several times; and at the end of each run after getting stable, a mark is made in the lower part of the disk on one of its faces. If the different marks are distributed randomly over the circumference of the disk, then the disk is of good mass distribution and considered balanced; but in the case that they accumulate in a small region, it is realised that there is a mass concentration in that part of the disk, and this can be treated either by taking small mass from there, or by adding mass to the opposite position of the disk.

Static Balancing Machine shown in *Figure-6.1* below is used for faster and more accurate static balancing operations. The machine is simply a pendulum, that is balanced and stable in a vertical configuration with no loading, and free to tilt in all directions about a ball joint; but when the pendulum is loaded with an unbalanced disk on its platform, it tilts by some angle from the original orientation. The side to which it tilts shows the position of the eccentric mass, and the angle by which it tilts θ is proportional to the magnitude of that eccentric mass to be compensated.

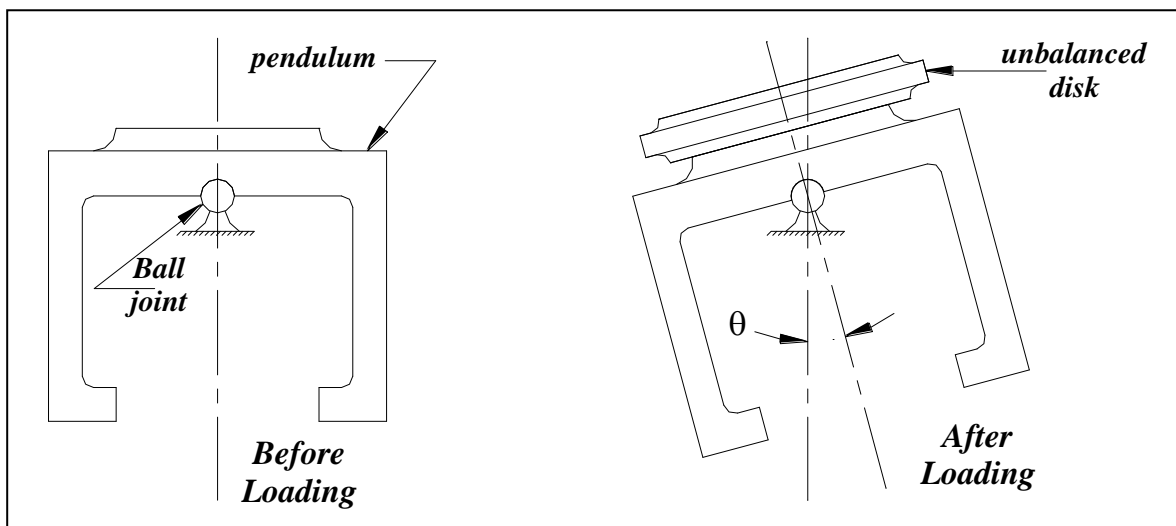

Figure-6.1 Schematic representation of the Static Balancing Machine

From the previous discussion, the only condition to be satisfied for static balancing to be achieved is that:-

“The resultant force of all the forces caused by the rotation of the out of balance masses, in a given rotating part should be zero”, that is:

$$\sum \vec{F}_i = 0 \quad (1)$$

The force F_i is given by:

$$F_i = m_i e_i \Omega^2 \quad (2)$$

where; m_i is the out of balance mass (*eccentric mass*).

e_i is the distance from axis of rotation (*eccentricity*).

Ω is the angular speed of the part.

(Note: eqn-1 is a vector equation, in which each force is a vector of a magnitude given by eqn-2, and direction denoted by the angle θ_i , measured from the reference horizontal direction).

Part Two- Dynamic Balancing:

Dynamic Balancing differs from static balancing in that the mass distribution of the part is detected in all directions, and not only about the central axis; and so, not only the magnitude of the unbalanced mass and its distance from the axis of rotation are to be determined, but also its position in the axial (*longitudinal*) direction of the rotational part.

To illustrate the meaning of this, consider a disk rotating with an angular speed Ω , with different out of balance masses m_i , each with eccentricity e_i from the axis of rotation. These masses are not expected to be in the same plane, but in different locations along the disk's axial direction; in addition, each mass will produce a centrifugal force making an angle θ_i with the reference horizontal direction in its own plane.

The system described previously and shown schematically in *Figure-6.2*, can be easily treated by choosing any plane as the reference for the other planes containing the eccentric masses, such that each one of them is at distance a_i from that reference plane.

And for simplicity, choose plane-1 as the reference plane, where a_1 becomes zero.

Generally, for the dynamic balancing of a system to be achieved, then:
 “The resultant force of all centrifugal forces caused by the out of balance masses should be zero (*as in static balancing*), in addition to that the summation of their moments about any point should be also zero”, that is:

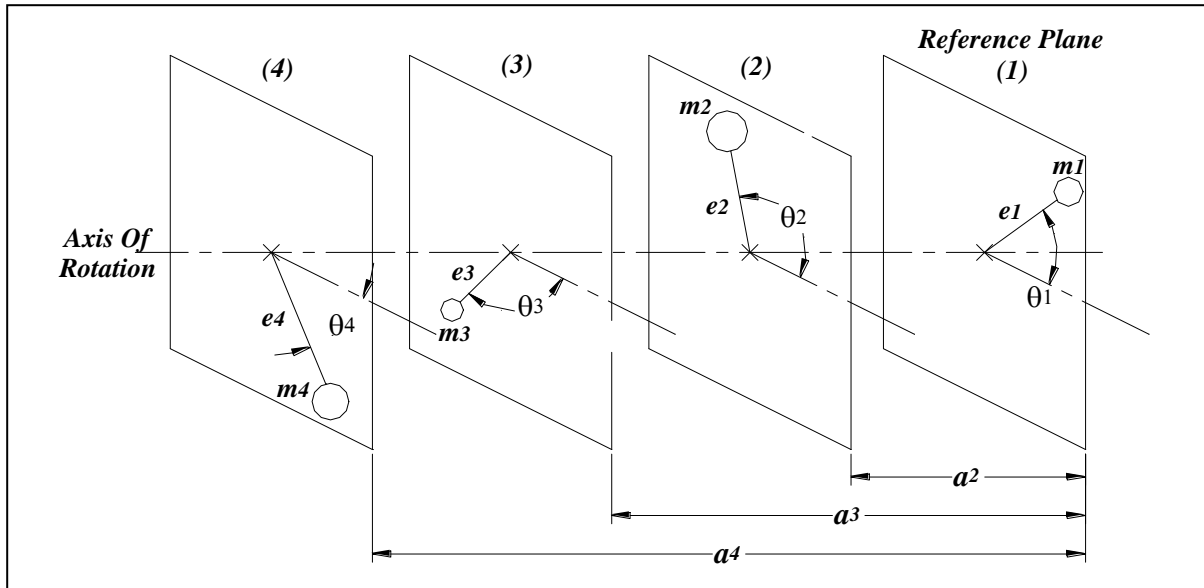

Figure-6.2 General case of a 3-D system to be dynamically balanced

$$\sum \vec{F}_i = 0 \tag{1}$$

$$\sum \vec{M}_i = 0 \tag{3}$$

And again, the forces in eqn-1 are given by eqn-2, and the moments in eqn-3 are given by:

$$M_i = a_i m_i e_i \Omega^2 \tag{4}$$

And so, after choosing a reference plane, translate all the centrifugal forces in the other planes to that plane as forces ($m_i e_i \Omega^2$) and moments ($a_i m_i e_i \Omega^2$), and there you can apply the vector summation of forces and moments separately to satisfy the requirements of dynamic balancing mentioned in eqns-1 & 3.

IV- System Description:

The system we are dealing with is shown in *Figure-6.3*, which consists of four blocks with the same geometry and dimensions, but each has a different size hole and so different eccentric mass. The four blocks are spaced along a shaft driven by an electrical motor, where each is fixed at distances S_i from its end, with angle θ_i measured from the horizontal direction.

The electrical motor is attached to the shaft by a flexible belt, and provides the shaft with rotation at various speeds; The shaft and the four blocks are carried on a circular table, which is attached to the rigid frame by flexible mountings that permits the sense of vibrations during the operation of the system.

The system in hand is to be balanced using the principles outlined before. The dimensions of all the blocks are provided, while the angular orientation and the distance from the end of the shaft are given for the first two blocks only; and so, you have to find the missing parameters of the other two blocks analytically, such that balancing state is accomplished.

V- Governing Equations:

In this experiment, the major formulas to be used have been given in *eqns-1, 2, 3 & 4*; and according to the given system, *eqns-1 & 3* can be extracted to:

$$\begin{aligned}\sum \vec{F}_i &= \vec{F}_1 + \vec{F}_2 + \vec{F}_3 + \vec{F}_4 = 0 \\ \Rightarrow m_1 e_1 \cos \theta_1 + m_2 e_2 \cos \theta_2 + m_3 e_3 \cos \theta_3 + m_4 e_4 \cos \theta_4 &= 0\end{aligned}\tag{5}$$

$$\Rightarrow m_1 e_1 \sin \theta_1 + m_2 e_2 \sin \theta_2 + m_3 e_3 \sin \theta_3 + m_4 e_4 \sin \theta_4 = 0\tag{6}$$

$$\begin{aligned}\sum \vec{M}_i &= \vec{M}_1 + \vec{M}_2 + \vec{M}_3 + \vec{M}_4 = 0 \\ \Rightarrow a_1 m_1 e_1 \cos \theta_1 + a_2 m_2 e_2 \cos \theta_2 + a_3 m_3 e_3 \cos \theta_3 + a_4 m_4 e_4 \cos \theta_4 &= 0\end{aligned}\tag{7}$$

$$\Rightarrow a_1 m_1 e_1 \sin \theta_1 + a_2 m_2 e_2 \sin \theta_2 + a_3 m_3 e_3 \sin \theta_3 + a_4 m_4 e_4 \sin \theta_4 = 0\tag{8}$$

To find the eccentric mass m and the eccentricity e for each block, then:
 According to *Figure-6.4* shown below, by assuming that the sector removed from the circle of diameter D_1 contributes approximately 90° of the full circle, then the eccentric mass and its eccentricity can be expressed by the following formulas, respectively:

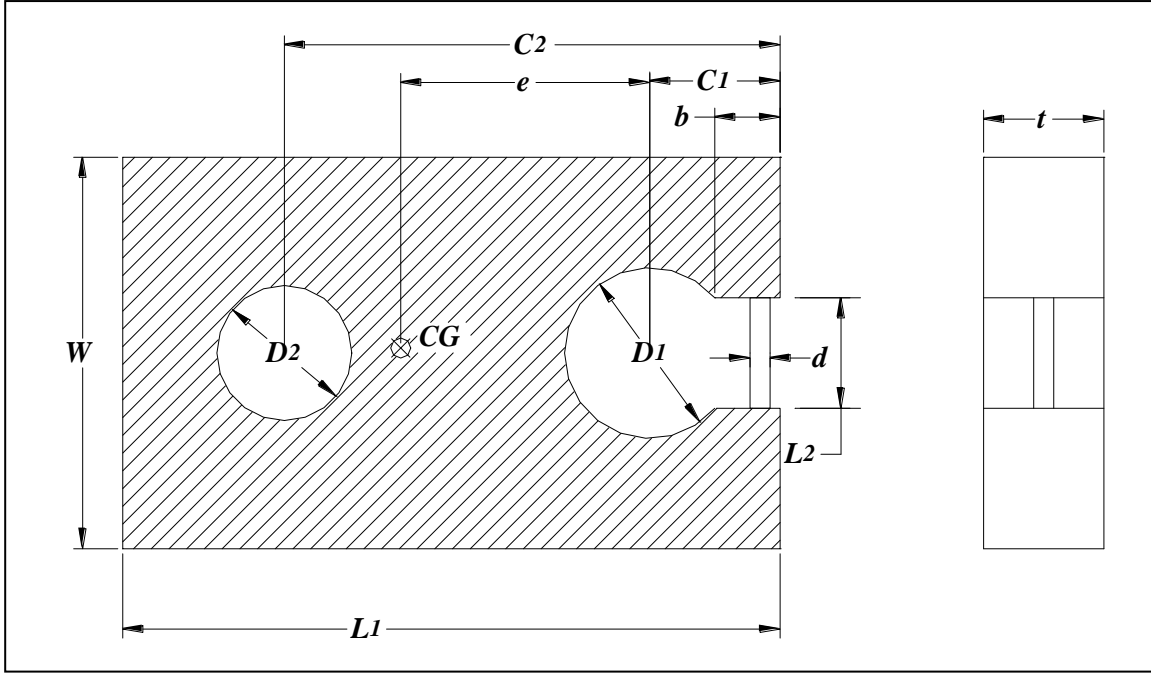

Figure-6.4 Nomenclature of the blocks

$$m = \rho \left(L_1 w t - \frac{\pi}{4} D_1^2 t - \frac{1}{8} D_1^2 t + \frac{\pi}{16} D_1^2 t - \frac{\pi}{4} D_2^2 t - b L_2 t + \frac{\pi}{4} d^2 L_2 \right) \quad (9)$$

$$e = \frac{\rho}{m} \left(\begin{aligned} &L_1 w t \left(\frac{L_1}{2} - C_1 \right) - \left(\frac{\pi}{16} D_1^2 t - \frac{1}{8} D_1^2 t \right) (C_1 - b) - \\ &\frac{\pi}{4} D_2^2 t (C_2 - C_1) + \left(b L_2 t - \frac{\pi}{4} d^2 L_2 \right) \left(C_1 - \frac{b}{2} \right) \end{aligned} \right) \quad (10)$$

VI- Experimental Procedures:

- 1- Take all the dimensions and perform your calculations as will be demonstrated, and complete balancing process of the rotating shaft by finding the missing variables.
- 2- Fix the four blocks on the rotating shaft with the corresponding longitudinal distances from its end a_i , and the angular orientations θ , according to your balancing calculations.
- 3- Connect the shaft to the motor through the flexible belt.
- 4- Run the motor, and vary its speed to observe the vibrations of the system.

According to your calculations, this configuration of the four blocks on the shaft should give a balanced rotating system, and you can check it out from the behaviour of the system as it should not generate any vibrations, and rotates smoothly.

To differentiate the behaviour of a balanced system from an unbalanced one, you can disturb the configuration of the four blocks with respect to each other (*change a or/and θ*), and rotate the shaft again, then notice the vibrations or fluctuations of the system.

VII- Collected Data:

Table-6.1 Basic dimensions of the four blocks

Differentiated Dimensions Among the Four Blocks				
Block	(1)	(2)	(3)	(4)
D_2 (mm)				
C_2 (mm)				

Shared Dimensions Among the Four Blocks			
Parameter	Value	Parameter	Value
D_1 (mm)		C_1 (mm)	
L_1 (mm)		L_2 (mm)	
t (mm)		w (mm)	
b (mm)		d (mm)	

Table-6.2 Data obtained concerning the first two blocks-1 & 2

Block	θ (°)	S (mm)
(1)		

(2)		
-----	--	--

VIII- Data Processing:

Use the dimensions measured, and apply in eqns-9 & 10 to find m and e for each block.	Determine the quantity me for the four blocks.	Determine the quantity ame for blocks-1 & 2. Note: $a_1 = 0 \Rightarrow a_1 m_1 e_1 = 0.$
On a graph paper, draw to scale from the origin the vector $m_1 e_1$ at the angle θ_1 , and then continue from its tip with the vector $m_2 e_2$ at angle θ_2 .	From the end of the second vector, draw a circle with radius $m_3 e_3$, and from the origin draw a circle of radius $m_4 e_4$.	Join the intersection point of the two circles with the end of vector-2 to get vector-3, and join it with the origin to get vector-4. Measure the angles of the two vectors θ_3 and θ_4 .
On another graph paper, draw from the origin the vector $a_1 m_1 e_1$ at the angle θ_1 , and then continue with $a_2 m_2 e_2$ at θ_2 .	From the end of the second vector, draw a line at angle θ_3 , and from the origin another one at angle θ_4 .	The intersection of them identifies vectors-3 & 4, and their lengths are $a_3 m_3 e_3$ and $a_4 m_4 e_4$, respectively. And so, you can find a_3 and a_4 , then S_3 and S_4 , according to your scale.

The previous method outlined is a graphical method, and you can obtain more accurate results by solving eqns-5 & 6 simultaneously, to find θ_3 and θ_4 , and then eqns-7 & 8 to get a_3 and a_4 .

* Note that:

$a_i = S_i - S_1$, as we have chosen plane-1 as the reference plane.

IX- Results:

Table-6.3 Data processing analysis

Block	<i>m</i> (kg)	<i>e</i> (mm)	<i>me</i> (kg.m)	<i>ame</i> (kg.m²)
(1)				
(2)				
(3)				-----
(4)				-----

Table-6.4 Data processing results

<i>From the two graphs:</i>			
Block	θ (°)	<i>ame</i> (kg.m²)	<i>a</i> (mm)
(3)			
(4)			

X- Discussion And Conclusions:

- 1) Name some practical examples in which balancing technique is necessary, and so employed?

- 2) For the disk mentioned in the example of static balancing technique, it was shown that it is statically balanced. Based on that description is it also dynamically balanced? Why?

- 3) It can be easily concluded that static balancing does not imply dynamic balancing. Describe how can you check that with the system used in the experiment, after being balanced?

- 4) Could we consider static balancing technique an adequate alternative for dynamic balancing in some special cases? If yes, explain when and give a practical example?

- 5) You are given a build-in system that you cannot change its configuration; like a shaft loaded with parts of known eccentric masses, at fixed separating distances and with fixed angular orientations. How could you balance such a system?

- 6) Comment on your observations concerning the behaviour of the system, when you had tested your balancing calculations experimentally?

Mass-Spring System

I- Objectives:

- 1) To determine the stiffness of a helical spring using two methods;
-Deflection curve and *Hook's Law*.
-Time measurements.
Then to compare their results with the analytical value.
- 2) To find the effective mass of the spring that has been used.
- 3) To evaluate the gravitational acceleration constant g .
- 4) To estimate the value of the modulus of rigidity G for the material of the helical spring, and compare it with the standard value for steel.

II- System Description:

The spring-mass system in *Figure-7.1* shows an extension linear helical spring with an initial free length L_i , effective mass m_s , supported vertically from one of its ends; while the other end is free to elongate and attached to a load-carrier of ($m_c = 1.47 \text{ kg}$) mass.

The free length of the spring loaded with the load carrier alone is L_o .

Disks each of ($m_d = 0.4 \text{ kg}$) mass are added to the carrier gradually, and each loading state causes the spring to elongate by the distance δ from its unloaded length L_o to get a total length of L .

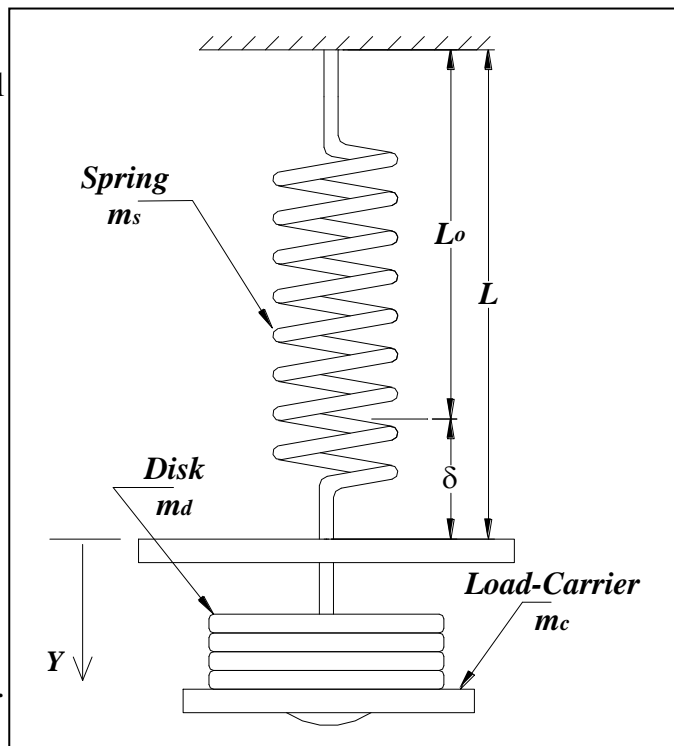

Figure-7.1 General layout of the experiment set-up

III- Governing Equations:

For the spring-mass system shown in *Figure-7.1*, in the case of free vibration in the vertical direction Y , the equation of motion of the system is given by:

$$M\ddot{y} + Ky = 0 \quad (1)$$

where:

M is the total mass of the system, and equals to:

$$M = m + m_c + m_s$$

m is the total mass of the disks

$$m = \sum m_d$$

From the equation of motion, we can find that:

$$* \text{ Natural frequency} = \omega_n = \sqrt{\frac{K}{M}} \quad (2)$$

$$* \text{ Period of oscillation} = \tau = \frac{2\pi}{\omega_n} = 2\pi\sqrt{\frac{M}{K}} = 2\pi\sqrt{\frac{m + m_c + m_s}{K}} \quad (3)$$

For the linear spring following *Hook's law*, then:

$$F_s = K\delta \quad (4)$$

But for the present system, the spring force F_s is also given by:

$$F_s = mg \quad (5)$$

Combine *eqns-4 & 5*, to get:

$$\Rightarrow m = \frac{K}{g}\delta \quad (6)$$

For a helical spring, the stiffness is expressed analytically as:

$$K = \frac{Gd^4}{8ND^3} \quad (7)$$

IV- Experimental Procedures:

- 1) Hang the spring vertically with the load carrier attached to its end, and then measure the total length of the spring L_o .
(This length is not the initial free length of the spring L_i)
- 2) Add one disk to the carrier ($m = m_d$), and measure the total length of the spring after elongation L .
- 3) With this loading, stretch the spring downward, then leave it to oscillate freely and record the time needed to complete ten oscillations T .
- 4) Add another disk so that ($m = 2m_d$), and repeat steps-2 & 3.
- 5) Continue by adding a disk each time for total ten disks ($m = 10m_d$), and each time measure the parameters L and T .

V- Collected Data:

Table-7.1 Data collected from the experiment execution

<i>Trial</i>	<i>m (kg)</i>	<i>L (cm)</i>	<i>T (second)</i>
<i>1</i>			
<i>2</i>			
<i>3</i>			
<i>4</i>			
<i>5</i>			
<i>6</i>			
<i>7</i>			
<i>8</i>			
<i>9</i>			
<i>10</i>			

Table-7.2 Dimensions and parameters of the spring

<i>Parameter</i>	<i>Value</i>
<i>N (turns)</i>	
<i>D (mm)</i>	
<i>d (mm)</i>	
<i>L_o (cm)</i>	

VI- Data Processing:

<p>Square <i>eqn-3</i>, to get:</p> $\tau^2 = \frac{4\pi^2}{K}(m + m_C + m_S)$	<p>Draw τ^2 versus m as shown in <i>Figure-7.2</i>.</p>	<p>1) Slope $S_1 = \frac{4\pi^2}{K}$ $\Rightarrow K$ is determined.</p> <p>2) Intercept with the vertical axis $Y_{Inter} = \frac{4\pi^2}{K}(m_C + m_S)$ $\Rightarrow m_S$ is determined.</p> <p>3) Intercept with the horizontal axis $X_{Inter} = -(m_C + m_S)$ $\Rightarrow m_S$ is verified.</p>
<p>From <i>eqn-6</i>:</p> $m = \frac{K}{g} \delta$	<p>Draw m versus δ as the one shown in <i>Figure-7.3</i>.</p>	<p>Slope $S_2 = \frac{K}{g}$ $\Rightarrow K$ is also obtained.</p>
<p>Multiply the slopes of the previous two steps.</p>	<p>You get the value:</p> $S_1 S_2 = \frac{4\pi^2}{g}$	<p>$\Rightarrow g$ is found, and compared to the standard value.</p>
<p>Use <i>eqn-7</i>:</p> $K = \frac{Gd^4}{8ND^3}$	<p>Find K directly.</p>	<p>Compare the two experimental values of K obtained before, with this theoretical value.</p>
<p>Square <i>eqn-3</i>, and eliminate K using <i>eqn-7</i>, then:</p> $\tau^2 = \left(\frac{32\pi^2 D^3 N}{Gd^4} \right) (m + m_C + m_S)$	<p>Using <i>Figure-7.2</i> of τ^2 versus m.</p>	<p>Slope $= \frac{32\pi^2 D^3 N}{Gd^4}$, \Rightarrow Determine G, and compare it with the standard value for steel.</p>

VII- Results:

Table-7.3 Data processing analysis

<i>Trial</i>	<i>m (kg)</i>	δ (mm)	τ (second)	τ^2 (second) ²
1				
2				
3				
4				
5				
6				
7				
8				
9				
10				

Table-7.4 Data processing results

Spring Stiffness K			
<i>K (theoretical) = (N/m)</i>			
<i>From:</i>	<i>Slope</i>	<i>K (N/m)</i>	<i>Percent Error (%)</i>
<i>Figure-3</i>			
<i>Figure-4</i>			

Spring Effective Mass m_s			
<i>From Figure-7.2:</i>			
<i>Y_{Inter} (kg.m/N)</i>		<i>m_s (kg)</i>	
<i>X_{Inter} (kg)</i>		<i>m_s (kg)</i>	

Gravitational Acceleration g			
<i>From Figures-7.2 & 4</i>	<i>S₁S₂ (sec²/m)</i>	<i>g (m/sec²)</i>	<i>Percent Error (%)</i>

Modulus Of Rigidity G			
<i>From Figure-7.2</i>	<i>Slope (m/N)</i>	<i>G (Gpa)</i>	<i>Percent Error (%)</i>

VIII- Discussion And Conclusions:

- 1) What is the physical meaning of the *Effective Mass* of a spring? Is there an effective mass for Torsion springs?

- 2) Derive a formula for the effective mass of a linear helical spring m_s in terms of its total mass M_s ?

- 3) Use the dimensions of the spring to estimate its volume and total mass (*by approximate calculations*), and apply in the formula derived above to find its effective mass. Verify your experimental results.

- 4) In eqn-5 $F_s = mg$, why didn't we equate the spring force F_s with the total weight of the system Mg ?

- 5) In determining the stiffness of the spring using the deflection curve of *Figure-7.3*, what is the essential implicit assumption that has been made? How could you ensure that you did not violate it in the experiment using your graph?

Centrifugal Force

I- Objectives:

In this experiment, the factors affecting the magnitude of the centrifugal force are to be studied separately

II- System Description:

Figure-8.1 below shows the layout of the system to be used in this experiment, in which a circular table is attached to an electrical motor, which drives it with rotational speed ω , and carries two blocks at opposite sides from the axis of rotation, each one can slide over a diametric rectangular way towards or away from the centre of the table.

Each block possesses a spider free to rotate about the axis passing through point O , at distance r from the axis of rotation. The two masses m_a and m_b are fixed at the two ends of the spider, each at a side from that axis, at distances r_a and r_b , respectively.

In the state of rotation, each upper mass m_a experiences a centrifugal force that tries to push it radial outwards, producing a moment that counteracts the moment caused by the weight of the lower mass m_b . By increasing the speed of rotation ω , the centrifugal force builds up until it reaches the required value to overcome the moment of the gravitational force; and there, the spider turns over.

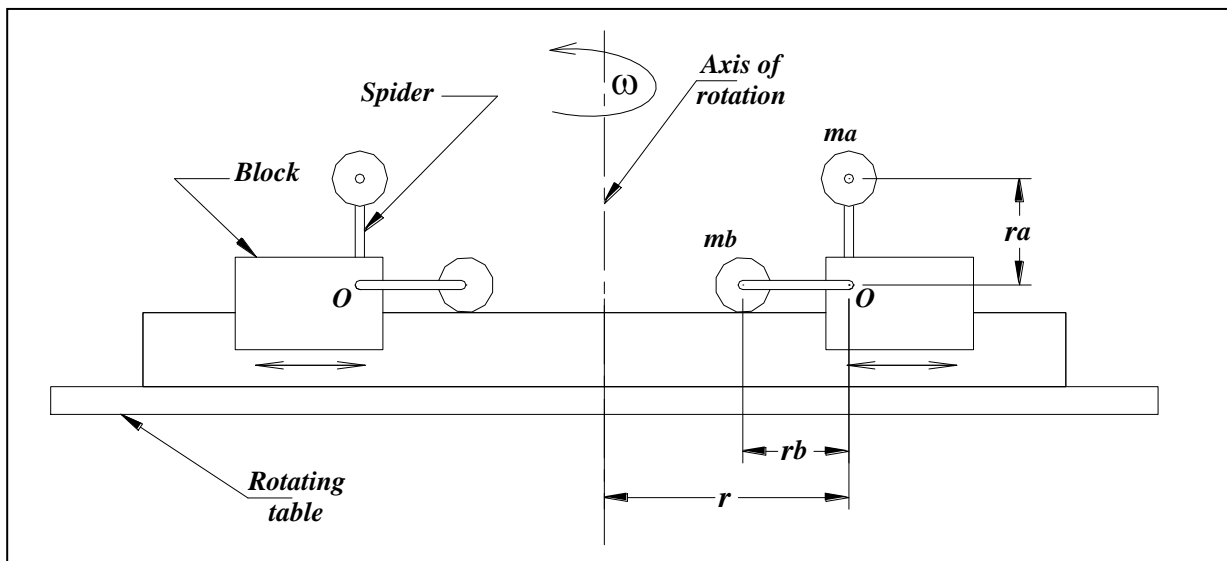

Figure-8.1 General layout of the experiment set-up

III- Governing Equations:

In the system shown in *Figure-8.1*, when the table rotates with an angular speed ω , then:

The summation of moments about point O will be:

$$\Sigma M = (m_b g)r_b - (m_a r\omega^2)r_a \quad (1)$$

At equilibrium state, at which the spider is just to turn over, the summation of moments about O becomes zero; and as the arms of the spider are of equal lengths ($r_a = r_b$), *eqn-1* yields:

$$m_b g = m_a r\omega^2 \quad (2)$$

That is at equilibrium; the centrifugal force acting on the upper mass m_a , should be equal to the weight of the lower mass m_b . And so you can evaluate the centrifugal force by either sides of *eqn-2*.

IV- Experimental Procedures:

- 1) Prepare the system shown in *Figure-8.1* with ($r = 12.5 \text{ cm}$), ($m_a = 25 \text{ gm}$) & ($m_b = 25 \text{ gm}$).
- 2) Switch the motor on at low speed, and then increase its speed slowly. During this, keep listening carefully until you hear a knocking sound, and there fix the speed and record it.

This sound indicates that the spider has turned over, and so equilibrium has been reached.

- 3) Keep r and m_a unchanged, and increase the value of m_b to ($50, 75$ and 100 gm), respectively. Repeat step-2 for each of the three cases.
- 4) With the same radius ($r = 12.5 \text{ cm}$); increase m_a to (50 gm) then to (75 gm). And for each one of them, repeat step-2 another four times corresponding to the same four values of m_b ($25, 50, 75$ and 100 gm).
- 5) Fix m_a at (25 gm), and reduce the radius r to (9.5 cm) then to (8 cm); and again for each one of the two radii, repeat step-2 four times, one corresponding to a value of m_b ($25, 50, 75$ and 100 gm).

Note: In each case before you run the motor, cover the table with the *Safety Dome*; this dome is a transparent plastic dome for protection during operation, and the motor switches of if it is not in place.

V- Collected Data:

Table-8.1 Data collected (speed of motor) for the mentioned states

$m_a = 25 \text{ gm}, \quad r = 12.5 \text{ cm}$		
<i>Trial</i>	<i>m_b (gm)</i>	<i>Speed (rpm)</i>
<i>1</i>	<i>25</i>	
<i>2</i>	<i>50</i>	
<i>3</i>	<i>75</i>	
<i>4</i>	<i>100</i>	

$m_a = 50 \text{ gm}, \quad r = 12.5 \text{ cm}$		
<i>Trial</i>	<i>m_b (gm)</i>	<i>Speed (rpm)</i>
<i>1</i>	<i>25</i>	
<i>2</i>	<i>50</i>	
<i>3</i>	<i>75</i>	
<i>4</i>	<i>100</i>	

$m_a = 75 \text{ gm}, \quad r = 12.5 \text{ cm}$		
<i>Trial</i>	<i>m_b (gm)</i>	<i>Speed (rpm)</i>
<i>1</i>	<i>25</i>	
<i>2</i>	<i>50</i>	
<i>3</i>	<i>75</i>	
<i>4</i>	<i>100</i>	

$m_a = 25 \text{ gm}, \quad r = 9 \text{ cm}$		
<i>Trial</i>	<i>m_b (gm)</i>	<i>Speed (rpm)</i>
<i>1</i>	<i>25</i>	
<i>2</i>	<i>50</i>	
<i>3</i>	<i>75</i>	
<i>4</i>	<i>100</i>	

$m_a = 25 \text{ gm}, \quad r = 8 \text{ cm}$		
<i>Trial</i>	<i>m_b (gm)</i>	<i>Speed (rpm)</i>
<i>1</i>	<i>25</i>	
<i>2</i>	<i>50</i>	
<i>3</i>	<i>75</i>	
<i>4</i>	<i>100</i>	

VI- Data Processing:

For each case mentioned before and presented in details in *Tables-8.1 & 2*, find the centrifugal force using the two terms (*sides*) of *eqn-3*. Then compare the two values as the left hand side represents the theoretical value, while the right hand side is the experimental one.

VII- Results:

Table-8.2 Data processing results

<i>$m_a = 25 \text{ gm}, \quad r = 12.5 \text{ cm}$</i>						
<i>Trial</i>	<i>m_b (gm)</i>	<i>ω (rad/sec)</i>	<i>$m_b g$ (N)</i>	<i>$m_a r \omega^2$ (N)</i>	<i>Percentage Error (%)</i>	
<i>1</i>	<i>25</i>					
<i>2</i>	<i>50</i>					
<i>3</i>	<i>75</i>					
<i>4</i>	<i>100</i>					

<i>$m_a = 50 \text{ gm}, \quad r = 12.5 \text{ cm}$</i>						
<i>Trial</i>	<i>m_b (gm)</i>	<i>ω (rad/sec)</i>	<i>$m_b g$ (N)</i>	<i>$m_a r \omega^2$ (N)</i>	<i>Percentage Error (%)</i>	
<i>1</i>	<i>25</i>					
<i>2</i>	<i>50</i>					
<i>3</i>	<i>75</i>					
<i>4</i>	<i>100</i>					

<i>$m_a = 75 \text{ gm}, \quad r = 12.5 \text{ cm}$</i>						
<i>Trial</i>	<i>m_b (gm)</i>	<i>ω (rad/sec)</i>	<i>$m_b g$ (N)</i>	<i>$m_a r \omega^2$ (N)</i>	<i>Percentage Error (%)</i>	
<i>1</i>	<i>25</i>					
<i>2</i>	<i>50</i>					
<i>3</i>	<i>75</i>					
<i>4</i>	<i>100</i>					

$m_a = 25 \text{ gm}, \quad r = 9 \text{ cm}$					
<i>Trial</i>	m_b (gm)	ω (rad/sec)	$m_b g$ (N)	$m_a r \omega^2$ (N)	<i>Percentage Error (%)</i>
1	25				
2	50				
3	75				
4	100				

$m_a = 25 \text{ gm}, \quad r = 8 \text{ cm}$					
<i>Trial</i>	m_b (gm)	ω (rad/sec)	$m_b g$ (N)	$m_a r \omega^2$ (N)	<i>Percentage Error (%)</i>
1	25				
2	50				
3	75				
4	100				

Simple Spring-Mass-Damper System

I- Introduction:

Generally speaking, vibratory systems consist basically of: potential energy storing element (*Stiffness*), kinetic energy storing element (*Mass or Inertia*) and energy dissipation element (*Damping*).

Damping effect in vibratory systems may be caused by surface friction between adjacent moving parts (*dry friction*), or due to plastic deformation and internal friction between layers of the material of the part (*structural damping*); and these two categories may not be eliminated perfectly, as they are uncontrollable. The third source of damping in vibrations is the use of mechanical viscous dampers, and this type with determinate value of damping is used to get the required damping effect. Generally, the first two types can be ignored in the analysis of vibrations under certain conditions, and a system under vibrations is treated as an un-damped vibrations case unless viscous dampers are employed.

II- Objectives:

In this experiment, a simple spring-mass-damper system is to be studied, in order to determine the damping coefficient C by two methods:

- Decaying curve method.
- Falling weight method.

III- System Description:

Figure-9.1 shows the system to be studied, which consists of a carriage of total mass ($M = 1.6 \text{ kg}$), that slides vertically up and down over two guide bars, while attached from its upper side by a spring of stiffness K , and from its lower side by a dashpot damper with damping coefficient C ; the spring and the damper are fixed to the main frame. The mass of the carriage can be increased by adding unit masses (*each of 1 kg*), as shown in the figure.

The dashpot used consists of two circular disks immersed in a container filled with oil; the lower disk has six equally-spaced holes, and attached directly to the carriage, while the upper one is solid, and able to turn around such that it approaches or departs from the lower one. The coefficient of damping of the dashpot varies according to the spacing between the two disks.

A rotating drum is provided beside the assembly, with a pencil attached to the carriage and in touch with the paper wrapped around the drum; this enables us to get the curve of motion for the carriage.

The whole system of the carriage, the spring and the dashpot can be represented schematically by a simple series combination of spring, mass and damper as also shown in *Figure-9.1*.

IV- Governing Equations:

By giving the system shown schematically in *Figure-9.1* an initial vertical displacement Y , it will vibrate freely with a time-varying function $y(t)$, and the resulting equation of motion will be:

$$M\ddot{y} + C\dot{y} + Ky = 0 \quad (1)$$

To solve for $y(t)$; let $y(t) = Ye^{st}$, then the auxiliary equation and its solutions are:

$$Ms^2 + Cs + K = 0$$

$$\Rightarrow s = -\frac{C}{2M} \pm \sqrt{\frac{C^2}{4M^2} - \frac{K}{M}} \quad (2)$$

Substitute in $y(t)$, to get:

$$y(t) = Y_1 e^{s_1 t} + Y_2 e^{s_2 t}$$

$$\Rightarrow y(t) = e^{-\frac{C}{M}t} \left[A_1 \sin \left(\sqrt{\frac{K}{M} - \frac{C^2}{4M^2}} t \right) + A_2 \cos \left(\sqrt{\frac{K}{M} - \frac{C^2}{4M^2}} t \right) \right] \quad (3)$$

But:

$$\zeta = \frac{C}{C_{Critical}} = \frac{C}{2\sqrt{KM}} = \frac{C}{2M\omega_n} \quad (4)$$

Then, *eqn-3* becomes:

$$\Rightarrow y(t) = e^{-\zeta\omega_n t} \left(A_1 \sin \left(\omega_n \sqrt{1 - \zeta^2} t \right) + A_2 \cos \left(\omega_n \sqrt{1 - \zeta^2} t \right) \right) \quad (5)$$

Part one- Decaying Curve Method:

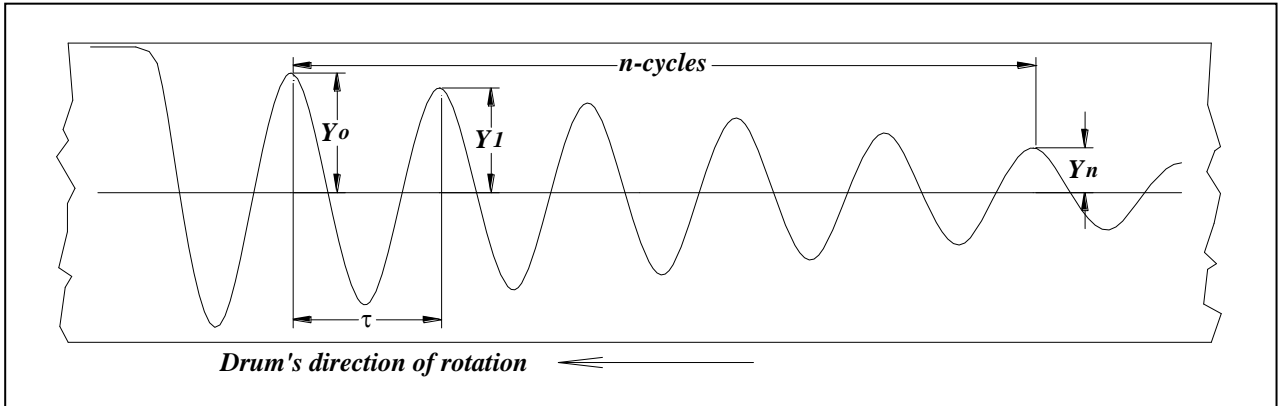

Figure-9.2 Decaying curve of a typical vibratory system for under-damping case

Considering a typical decaying curve as the one shown in *Figure-9.2* above, then the ratio of the amplitude Y_o corresponding to the time $t = t_o$, to the amplitude Y_n at time $t = t_o + n\tau$, is given by:-

$$\frac{Y_o}{Y_n} = \frac{e^{-\zeta\omega_n t_o}}{e^{-\zeta\omega_n(t_o+n\tau_d)}} = e^{n\zeta\omega_n\tau_d} \quad (6)$$

Define the Logarithmic Decrement δ as:

$$\delta = \frac{1}{n} \ln\left(\frac{Y_o}{Y_n}\right) \quad (7)$$

Eliminate $\ln\left(\frac{Y_o}{Y_n}\right)$ from eqns-6 & 7, to obtain an expression for ζ as:

$$\delta = \zeta\omega_n\tau_d = \frac{2\pi\zeta}{\sqrt{1-\zeta^2}}$$

$$\Rightarrow \zeta = \frac{\delta}{\sqrt{\delta^2 + 4\pi^2}} \quad (8)$$

Then eqn-4 is used to find the damping coefficient, where:

$$\omega_n = \sqrt{\frac{K}{M}} \quad (9)$$

$$K = \frac{Gd^4}{8ND^3} \quad (10)$$

Part Two- Falling Weight Method:

In the original system used before, if the spring were removed leaving only the mass and the damper, and the new assembly is pulled up and then left to fall down freely; then the only force that will act against the motion due to the weight of the mass is the resistive damping force of the dashpot.

For dynamic equilibrium state to be reached, these two forces should be equal, That is:

$$Mg = CV$$

$$\Rightarrow C = \frac{Mg}{V} \tag{11}$$

where; V is the velocity of the falling carriage.

The velocity of the carriage V can be obtained by drawing the curve of motion while moving downwards, as shown in *Figure-9.3*; in which a linear segment of the obtained curve is considered, where the horizontal and vertical displacements are X & Y , respectively.

From this line we can find out that:

$$t = \frac{X}{V_x} = \frac{Y}{V_y} \tag{12}$$

where; t is the time elapsed in travelling along that segment

V_x is the horizontal speed, which is the drum's circumferential speed

V_y is the vertical speed, which is the speed of the falling carriage V

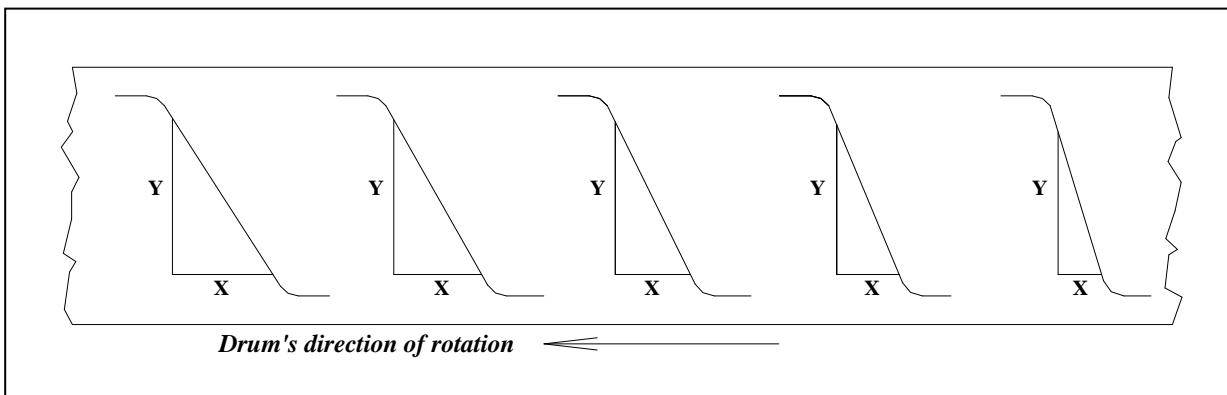

Figure-9.3 Response curve of a typical mass-damper system

V- Experimental Procedures:

Part one- Decaying Curve Method:

- 1) Start with the system shown in *Figure-9.1* without additive masses, and with the damper fully closed (*The two disks are in touch with no clearance*).
- 2) Install the paper roll in place and wrap it over the drum, then make the pen in touch with the drum over the paper.
- 3) Pull the carriage down and switch the motor of the drum on, and keep it like this for a moment to get a straight line on the paper at first; then release the carriage and leave it to oscillate freely, and draw the decaying curve of its motion on the paper, as the one shown in *Figure-9.2*.
- 4) Repeat step-3 another four times; and in each one increase the clearance between the two disks of the damper, by revolving the upper disk one complete turn. After completing the five trials, remove the paper to be used in your calculations.
- 5) Add a unit mass (*1 kg*) to the carriage ($\Rightarrow M= 2.6 \text{ kg}$), and then repeat steps-2, 3 & 4.
- 6) Add another unit mass and repeat steps-2, 3 & 4 again.

Part Two- Falling Weight Method:

- 1) Remove the spring and the additive masses from the system, and close the damper again.
- 2) Install another paper on the drum; then pull the carriage upwards and activate the motor of the drum for a while, then release the carriage to fall freely in the dashpot.
- 3) Repeat step-2 four times again by revolving the upper disk one turn for each. The curve you obtain should be similar to that in *Figure-9.3*.
- 4) Add (*1 kg*), and then add another one; and for each loading case, repeat steps-2 & 3.

VI- Collected Data:

Table-9.1 Parameters of the spring

Parameter	Value
D (mm)	
d (mm)	
N (turn)	

VII- Data Processing:

Part one- Decaying Curve Method:

From the decaying curve in Figure-9.2: Use eqn-7 to find δ , and then apply in eqn-8 to find ζ .	From eqns-9 & 10, evaluate K and ω_n .	Find C from eqn-4, corresponding to each state listed later.
--	---	--

Part Two- Falling Weight Method:

From the curve of free falling in Figure-9.3, and using eqn-12, find the velocity V .	Substitute in eqn-11 to find C .	For each state, compare the value of C you obtain by this method, with the corresponding value obtained by the decaying curve method before.
---	------------------------------------	--

VIII- Results:

$K = \dots\dots\dots(N/m).$

$V_x = \dots\dots\dots (m/s).$

Part one- Decaying Curve Method:

Table-9.2 Data processing results

$M = 1.6 \text{ kg: } \omega_n = \dots\dots\dots(\text{rad/sec})$				
<i>Trial</i>	<i>Upper disk turns</i>	δ	ζ	C (N.s/m)
<i>1</i>	<i>0</i>			
<i>2</i>	<i>1</i>			
<i>3</i>	<i>2</i>			
<i>4</i>	<i>3</i>			
<i>5</i>	<i>4</i>			

$M = 2.6 \text{ kg: } \omega_n = \dots\dots\dots(\text{rad/sec})$				
<i>Trial</i>	<i>Upper disk turns</i>	δ	ζ	C (N.s/m)
<i>1</i>	<i>0</i>			
<i>2</i>	<i>1</i>			
<i>3</i>	<i>2</i>			
<i>4</i>	<i>3</i>			
<i>5</i>	<i>4</i>			

$M = 3.6 \text{ kg: } \omega_n = \dots\dots\dots(\text{rad/sec})$				
<i>Trial</i>	<i>Upper disk turns</i>	δ	ζ	C (N.s/m)
<i>1</i>	<i>0</i>			
<i>2</i>	<i>1</i>			
<i>3</i>	<i>2</i>			
<i>4</i>	<i>3</i>			
<i>5</i>	<i>4</i>			

Part Two- Falling Weight Method:

Table-9.3 Data processing results

<i>M = 1.6 kg</i>				
<i>Trial</i>	<i>Upper disk turns</i>	<i>V (m/s)</i>	<i>C (N.s/m)</i>	<i>Percent Error (%)</i>
<i>1</i>	<i>0</i>			
<i>2</i>	<i>1</i>			
<i>3</i>	<i>2</i>			
<i>4</i>	<i>3</i>			
<i>5</i>	<i>4</i>			

<i>M = 2.6 kg</i>				
<i>Trial</i>	<i>Upper disk turns</i>	<i>V (m/s)</i>	<i>C (N.s/m)</i>	<i>Percent Error (%)</i>
<i>1</i>	<i>0</i>			
<i>2</i>	<i>1</i>			
<i>3</i>	<i>2</i>			
<i>4</i>	<i>3</i>			
<i>5</i>	<i>4</i>			

<i>M = 3.6 kg</i>				
<i>Trial</i>	<i>Upper disk turns</i>	<i>V (m/s)</i>	<i>C (N.s/m)</i>	<i>Percent Error (%)</i>
<i>1</i>	<i>0</i>			
<i>2</i>	<i>1</i>			
<i>3</i>	<i>2</i>			
<i>4</i>	<i>3</i>			
<i>5</i>	<i>4</i>			

IX- Discussion And Conclusions:

- 1) Draw the damping coefficient C ($N.s/m$), versus disks spacing ($turn$), for the different values of M .

- 2) It is known that the damping coefficient for the viscous damper is independent of the attached mass. How dose this statement coincides with *eqn-11*? Verify this from your results?

- 3) In *eqn-11*, it was claimed that the velocity of the falling mass is constant. Is this correct? Why? Give a proof for your answer from your results.

- 4) List the expected sources of errors affecting the results of the experiment?

- 5) During the execution of the experiment, did the resulted decaying curve violate the expected one shown in *Figure-9.2*? When? Why? And how could you alter the situation?

Transverse Vibrations of a Beam

I- Objectives:

- 1) To introduce “*Dunkerley’s Equation*”, and demonstrate its use in studying transverse vibrations of beams.
- 2) To recognise the application of this equation on a simply supported beam, for the aim of:
 - 1- Determining the natural frequency ω_n of the simply supported beam, and then to compare it with the analytical value.
 - 2- Evaluation of its effective mass M_{Eff} , and then comparing it with the theoretical value.
 - 3- Determining the stiffness of the beam K , to be compared with the theoretical value.
- 3) To demonstrate the principle of operation of the “*Un-damped Dynamic Vibration Absorber*” in eliminating vibrations of single degree of freedom systems.

II- System Description:

The system under study is shown in *Figure-10.1* below, which consists of a simply supported rectangular cross-section beam, of known dimensions L , w & t , modulus of elasticity E , total mass M_b and effective mass M_{Eff} .

Auxiliary masses (*disks*) M may be added to the system.

An electrical motor with mass ($M_m = 3 \text{ kg}$) is fixed on the beam, and rotates a circular disk with eccentric mass to induce vibrations on the system.

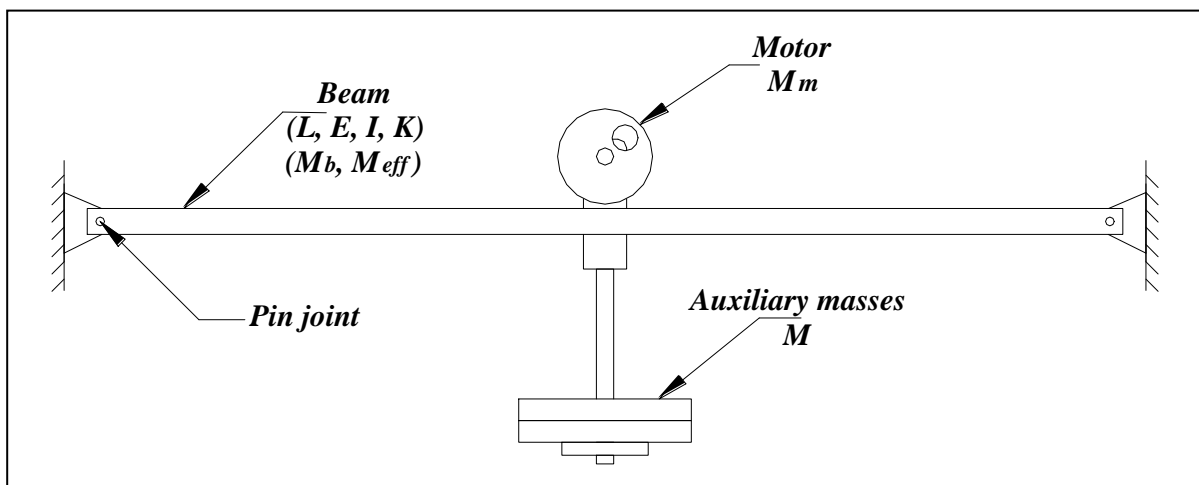

Figure-10.1 General layout of the experiment set-up

III- Governing Equations:

Part One- Dunkerley's Equation:

For the system shown in *Figure-10.1*, the equation of motion is given by:

$$(M + M_{Eff})\ddot{Y} + KY = 0 \quad (1)$$

From which the natural frequency of the whole system ω_{ns} is found as:

$$\omega_{ns} = \sqrt{\frac{K}{M + M_{Eff}}} \quad (2)$$

Square and expand this equation to get:

$$\begin{aligned} \frac{1}{\omega_{ns}^2} &= \frac{M}{K} + \frac{M_{Eff}}{K} \\ \Rightarrow \frac{1}{\omega_{ns}^2} &= \frac{1}{\omega_{nm}^2} + \frac{1}{\omega_{nb}^2} \end{aligned} \quad (3)$$

This equation is known as the “*Dunkerley's Equation*”, where:

ω_{ns} is the natural frequency of the hole system.

ω_{nm} is the natural frequency of the motor.

ω_{nb} is the natural frequency of the beam.

Analytical Solution:

1. Natural Frequency (ω_{nb}):

Analytically, for a simply supported beam, an expression for the natural frequency ω_n can be derived to give:

$$\omega_n = \pi^2 \sqrt{\frac{EI}{\rho AL^4}} = \pi^2 \sqrt{\frac{EI}{M_b L^3}} \quad (4)$$

2. Effective Mass (M_{Eff}):

The effective mass M_{Eff} of a simply supported beam is given in terms of its total mass M_b by the expression:

$$M_{Eff} = \frac{17}{35} M_b = 0.485714 M_b \quad (5)$$

Knowing that:

- Deflection of the simply supported beam $y(x)$:

$$y(x) = \frac{Fx}{48EI} (4x^2 - 3L^2) \quad (6)$$

- Maximum deflection y_{Max} :

$$y_{Max}(x) = \frac{-FL^3}{48EI} \quad (7)$$

- Kinetic energy T :

$$T = 2 \int_0^{L/2} \frac{1}{2} \dot{y}^2 . dm = 2 \frac{M_b}{L} \int_0^{L/2} \dot{y}^2 . dx \quad (8)$$

3. Stiffness (K):

From eqn-7, it can be easily concluded that the stiffness of the simply supported beam K is equal to:

$$K = \frac{48EI}{L^3} \quad (9)$$

Part Two- Vibration Absorber:

The *Vibration Absorber* is a secondary vibratory system attached to a primary one, such that it eliminates the vibrations of that primary system. One type of such absorbers is the *Un-damped Dynamic Vibration Absorber*, which is simply a spring-mass system.

Figure-10.2 below shows a form of such vibration absorbers; in which a cantilever beam having two identical masses at both ends -each at distance L_c - is fitted to the system used before and shown in Figure-10.1 without the auxiliary masses.

The new system can be represented by a two-degrees of freedom system as the one shown schematically also in Figure-10.2, where:

M_1 is the mass of the primary system (*the beam and the motor*).

M_2 is the mass of the secondary system (*each of the two suspended masses*).

K_1 is the stiffness of the simply supported beam.

K_2 is the stiffness of the cantilever beam.

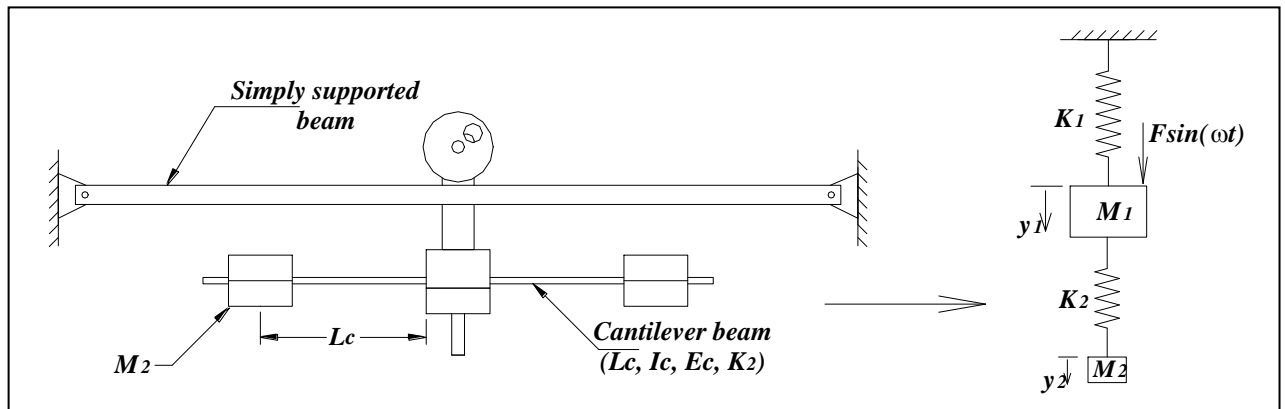

Figure-10.2 General layout of the original system after the addition of the vibration absorber

Taking each system separately (*primary & secondary*), the equations of motion for the two systems are given by:

$$M_1 \ddot{y}_1 + K_1 y_1 + K_2 (y_1 - y_2) = F \sin(\omega t) \quad (10)$$

$$M_2 \ddot{y}_2 + K_2 (y_2 - y_1) = 0 \quad (11)$$

From which the steady state response is found for both as:

$$Y_1 = \frac{(K_2 - M_2 \omega^2) F}{(K_1 + K_2 - M_1 \omega^2)(K_2 - M_2 \omega^2) - K_2^2} \quad (12)$$

$$Y_2 = \frac{K_2 F}{(K_1 + K_2 - M_1 \omega^2)(K_2 - M_2 \omega^2) - K_2^2} \quad (13)$$

But:

$$\delta_{Static} = \frac{F}{K_1} \quad (14)$$

So, eqn-12 becomes:

$$\frac{Y_1}{\delta_{Static}} = \frac{1 - \left(\frac{\omega}{\omega_{n1}}\right)^2}{\left[\left(1 + \left(\frac{K_2}{K_1}\right) - \left(\frac{\omega}{\omega_{n1}}\right)^2\right) \left(1 - \left(\frac{\omega}{\omega_{n2}}\right)^2\right) \right] - \frac{K_2}{K_1}} \quad (15)$$

Figure-10.3 below shows a graph of $\frac{Y_1}{\delta_{Static}}$ versus $\frac{\omega}{\omega_{n1}}$ for the primary system.

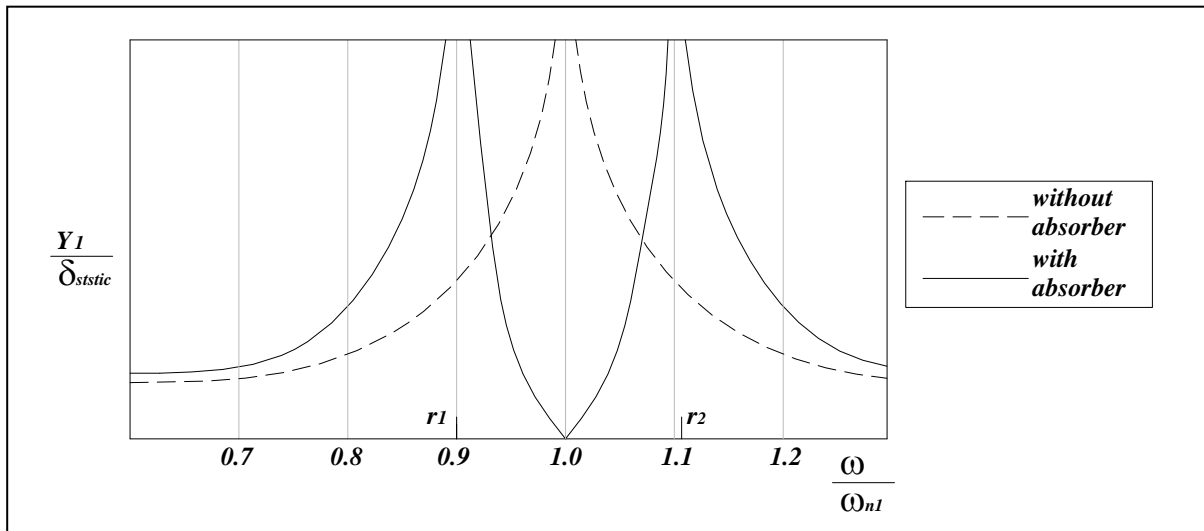

Figure-10.3 Magnification factor versus frequency ratio for the primary system

Considering eqns-12 & 15, to eliminate the vibrations of the primary system, then:

$$Y_1 = 0$$

$$\Rightarrow K_2 - M_2 \omega^2 = 0$$

$$\Rightarrow \omega^2 = \frac{K_2}{M_2}$$

But, at the state of resonance of the primary system:

$$\omega^2 = \omega_{n1}^2 = \frac{K_1}{M_1}$$

$$\Rightarrow \frac{K_1}{M_1} = \frac{K_2}{M_2} \quad (16)$$

That is, the natural frequency of the primary system should be equal to that of the secondary systems, and so:

$$\omega_R^2 = \frac{3E_C I_C}{M_2 L_C^3} \quad (17)$$

To find the values of r_1 and r_2 in *Figure-10.3*, then:

$$Y_1 = \infty$$

$$\Rightarrow (K_1 + K_2 - M_1 \omega^2)(K_2 - M_2 \omega^2) - K_2^2 = 0$$

Define:

$$r = \frac{\omega}{\omega_n}, \quad R_M = \frac{M_2}{M_1}$$

$$\Rightarrow r^4 - (2 + R_M)r^2 + 1 = 0$$

$$\Rightarrow r_{1,2}^2 = \frac{2 + R_M \pm \sqrt{R_M^2 + 4R_M}}{2} \quad (18)$$

From *eqn-18* we can find that:

$$\left\{ \begin{array}{l} r_1 r_2 = 1 \\ r_1^2 + r_2^2 = 2 + R_M \end{array} \right\} \quad (19)$$

IV- Experimental Procedures:

Part One- Dunkerley's Equation:

- 1) Start with the system shown in *Figure-10.1* without any additional masses, and activate the motor to initiate vibrations on the beam.
- 2) Increase the speed gradually and observe the behaviour of the system, until you identify the resonance state where maximum amplitude of vibrations takes place, then record the speed of the motor N_R .
- 3) Add a unit mass (1 kg) to the beam; and again, record the speed of the motor at resonance N_R .
- 4) Repeat step-3 another five times to get total seven pairs of M and N_R .

Part Two- Vibration Absorber:

- 1) Replace the auxiliary masses in the original system by the vibration absorber as shown in *Figure-10.2*, with the two masses at the extreme ends of the cantilever beam.
- 2) Run the motor at the same speed corresponding to resonance that you have obtained for the system without auxiliary masses in the first part (N_R at $M = 0$); then slide the two masses slowly on the cantilever beam by equal distances, until you detect the best sense of elimination of vibrations of the simply supported beam. Record the length L_C .
- 3) Keep the vibration absorber in the previous modified configuration, and run the motor at low speed. Increase the speed slowly, and determine the speed of the motor at each one of the two cases of resonance shown in *Figure-10.3*; that is, N_1 and N_2 corresponding to r_1 and r_2 , respectively.

V- Collected Data:

Part One- Dunkerley's Equation:

Table-10.1 Dimensions of the beam

Parameter	Value
<i>L (cm)</i>	
<i>w (mm)</i>	
<i>t (mm)</i>	

Table-10.2 Data collected for the Dunkerley's Equation part

Trial	M (kg)	N_R (rpm)
1	0	
2	1	
3	2	
4	3	
5	4	
6	5	
7	6	

Part Two- Vibration Absorber:

Table-10.3 Parameters of the cantilever beam and the suspended masses

Parameter	Value
<i>L_C (cm)</i>	
<i>w_C (mm)</i>	
<i>t_C (mm)</i>	
<i>M₂ (kg)</i>	

Table-10.4 Data collected for the Vibration Absorber part

Parameter	Value
<i>N₁ at r₁ (rpm)</i>	

N_2 at r_2 (rpm)	
----------------------	--

VI- Data Processing:

Part One- Dunkerley's Equation:

For each value of N_R obtained, find the corresponding natural frequency for the system ω_{ns} .	Draw $\left(\frac{1}{\omega_{ns}}\right)^2$ versus M , as shown in <i>Figure-10.4</i> .	1) Slope = $\frac{1}{K}$ $\Rightarrow K$ is determined. 4) Intercept with the vertical axis $Y_{Inter} = \left(\frac{1}{\omega_{nb}}\right)^2$ $\Rightarrow \omega_{nb}$ is found. 5) Intercept with the horizontal axis $X_{Inter} = -M_{Eff}$ \Rightarrow Verify M_{Eff} .
From <i>eqn-5</i> , find M_{Eff}		Compare it with the experimental value.
Determine K from <i>eqn-9</i>		Compare it with the experimental value.
Use <i>eqn-4</i> to find ω_{nb}		Compare it with the experimental values.

Part Two- Vibration Absorber:

Apply in <i>eqn-17</i> , with $\omega_n = \omega_{n1}$ to find L_C for the cantilever beam.	Compare L_C calculated with that obtained experimentally.
Use <i>eqn-18</i> to evaluate r_1 and r_2 .	Compare these values with those observed experimentally. Then verify your experimental results using <i>eqn-19</i> .

VII- Results:

Part One- Dunkerley's Equation:

Table-10.5 Data processing analysis for the Dunkerley's Equation part

Theoretically:	
M_{Eff} (kg)	
K (N/m)	
ω_{nb} (rad/sec)	

Table-10.6 Data processing results for the Dunkerley's Equation part

From Figure-10.4		
$Slope$ (m/N)	K (N/m)	Percent Error (%)
Y_{Inter} (sec/rad) ²	ω_{nb} (rad/sec)	Percent Error (%)
X_{Inter} (kg)	M_{Eff} (kg)	Percent Error (%)

Part Two- Vibration Absorber:

Table-10.7 Data processing results for the Vibration Absorber part

Parameter	Theoretical	Experimental	Percent Error (%)
L_c (mm)			
r_1			
r_2			

